

## Industrial Peristaltic Pumps FMP-50/B Data sheet

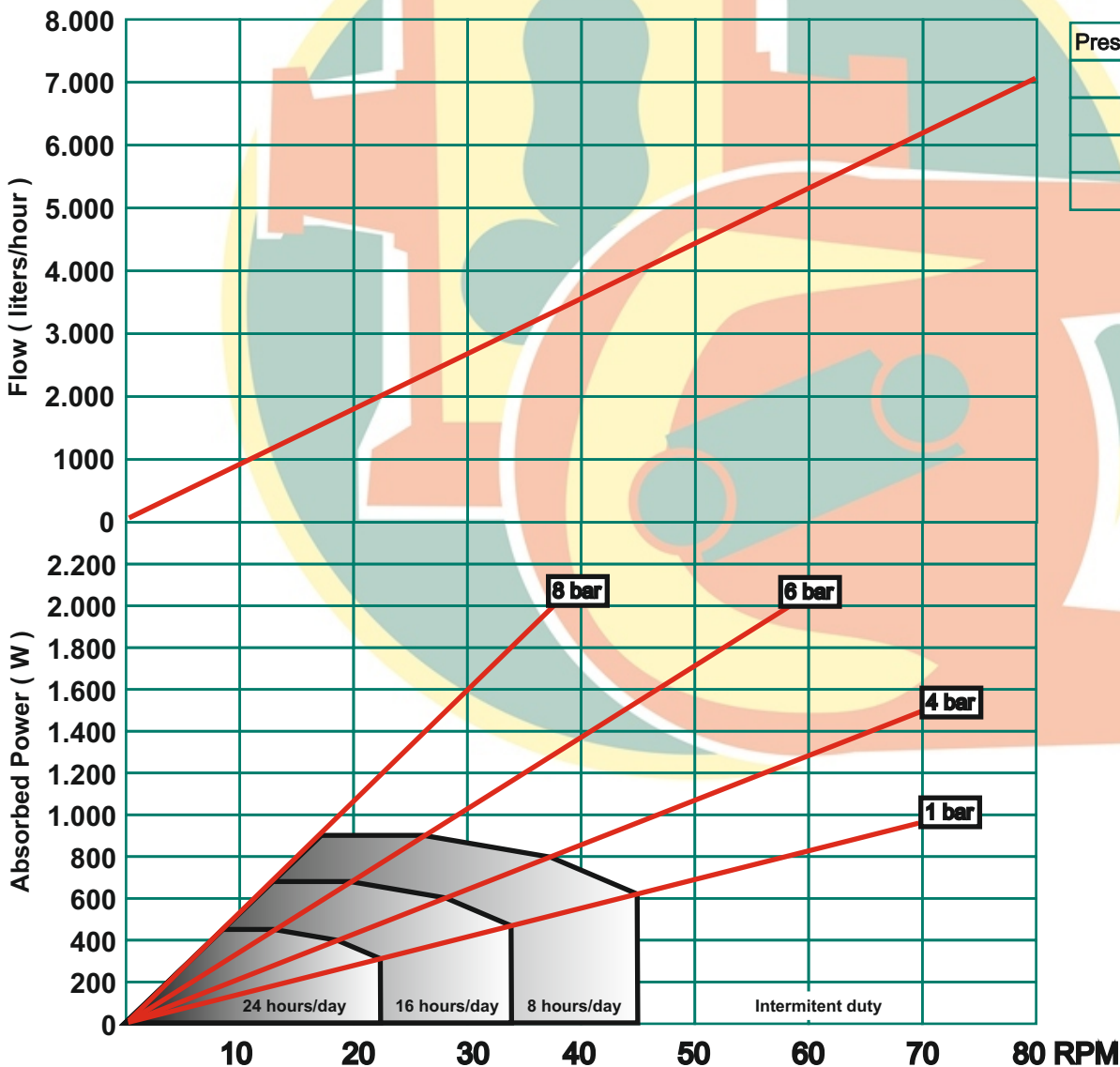

**Capacity:** 1,47 l/rev.  
**Connections:** DN-40  
**Max. Pressure:** 8 bar  
**Rotor system:** Enlarged Rollers  
**Available hoses:** NR  
 NBR  
 EPDM  
 HYPALON  
 NR-A  
 NBR-A  
**Available tubes:** Norprene



Description	Material	Surface treatment
Pump housing	Cast Iron EN-GJL-250	Polyester powder coated Halar coated ( Optional )
Front cover	Steel F-111 / Polycarbonate	Polyester powder coated Halar coated ( Optional )
Rotor	Nodular Cast Iron EN-GJL-400	Cataforesis
Rollers	Steel F-114 + Polyurethane	--
Base plate	Steel F-111 Stainless Steel AISI-304 ( Optional )	Polyester powder coated --
Connections	Stainless Steel AISI-316 Polypropylene ( Optional ) PVDF ( Optional )	--

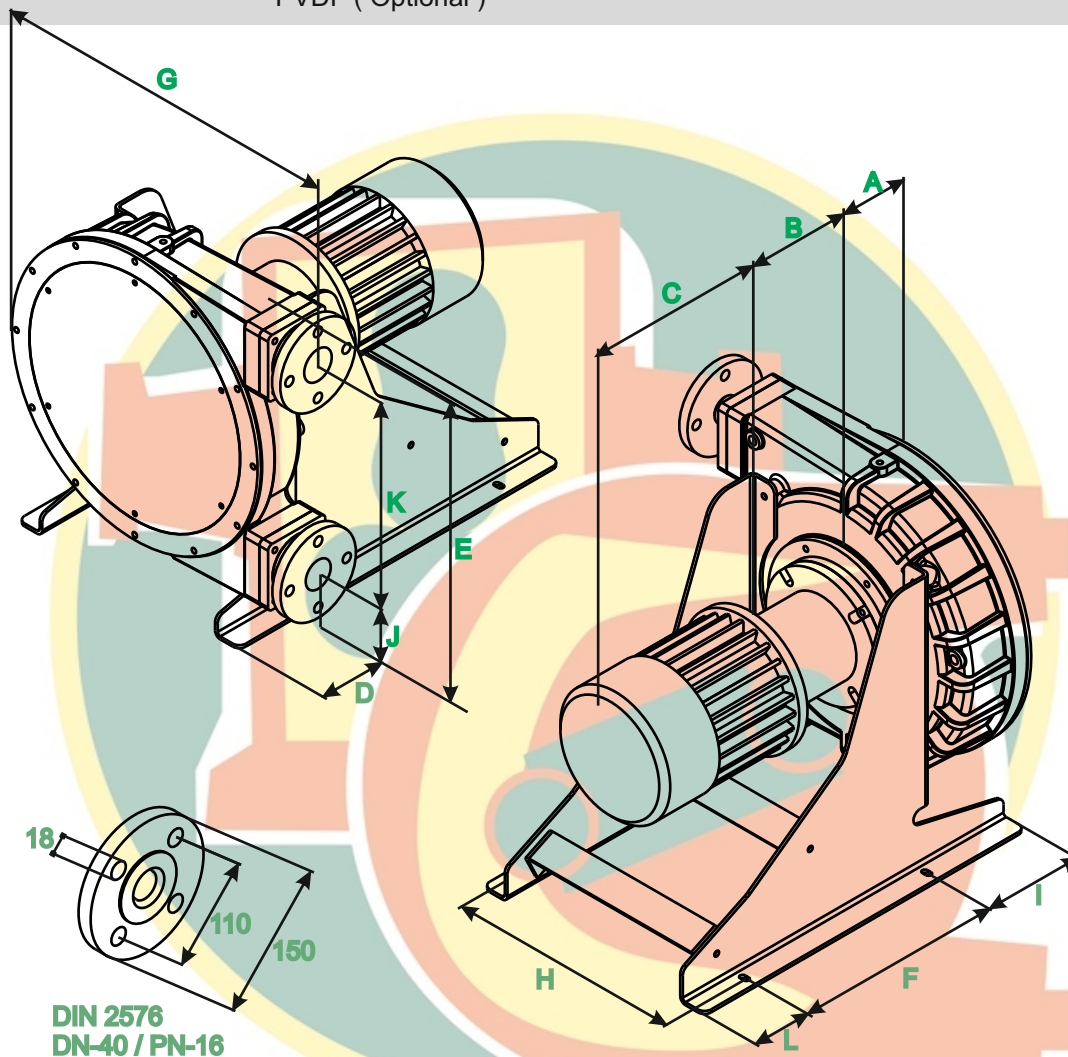

A	B	C	D	E	F	G	H	I	J	K	L
151	•	•	79	645	415	633	453	200	169	412	115

\* To confirm according type and power driver.

