

## Industrial Peristaltic Pumps

### RBT-40 Data sheet

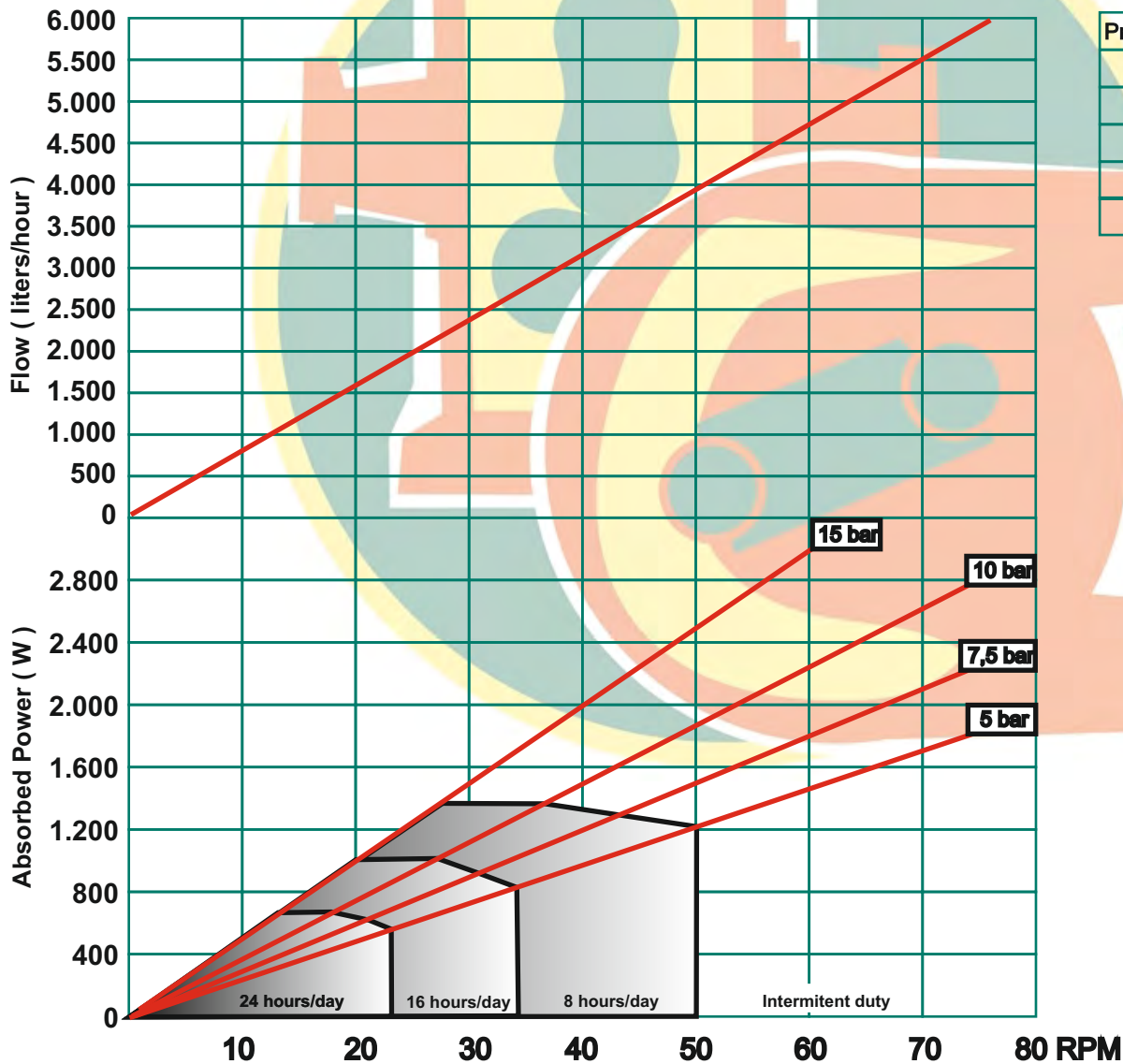

**Capacity:** 1,33 l/rev.  
**Connections:** DN-40  
**Max. Pressure:** 15 bar  
**Rotor system:** Shoes  
**Available hoses:** NR  
 NBR  
 EPDM  
 HYPALON  
 NR-A  
 NBR-A



Pressure (bar)	Torque (Nm)
Minimum	310
5	310
7,5	310
10	365
15	480



Description	Material	Surface treatment
Pump housing	Cast Iron EN-GJL-250	Polyester powder coated Halar coated ( Optional )
Front cover	Steel F-111 / Methacrilate	Polyester powder coated Halar coated ( Optional )
Rotor	Nodular Cast Iron EN-GJL-400	Cataforesis
Shoes	Nodular Cast Iron EN-GJL-400	Hardened
Base plate	Steel F-111 Stainless Steel AISI-304 ( Optional )	Polyester powder coated --
Connections	Stainless Steel AISI-316 Polypropylene ( Optional ) PVDF ( Optional )	--

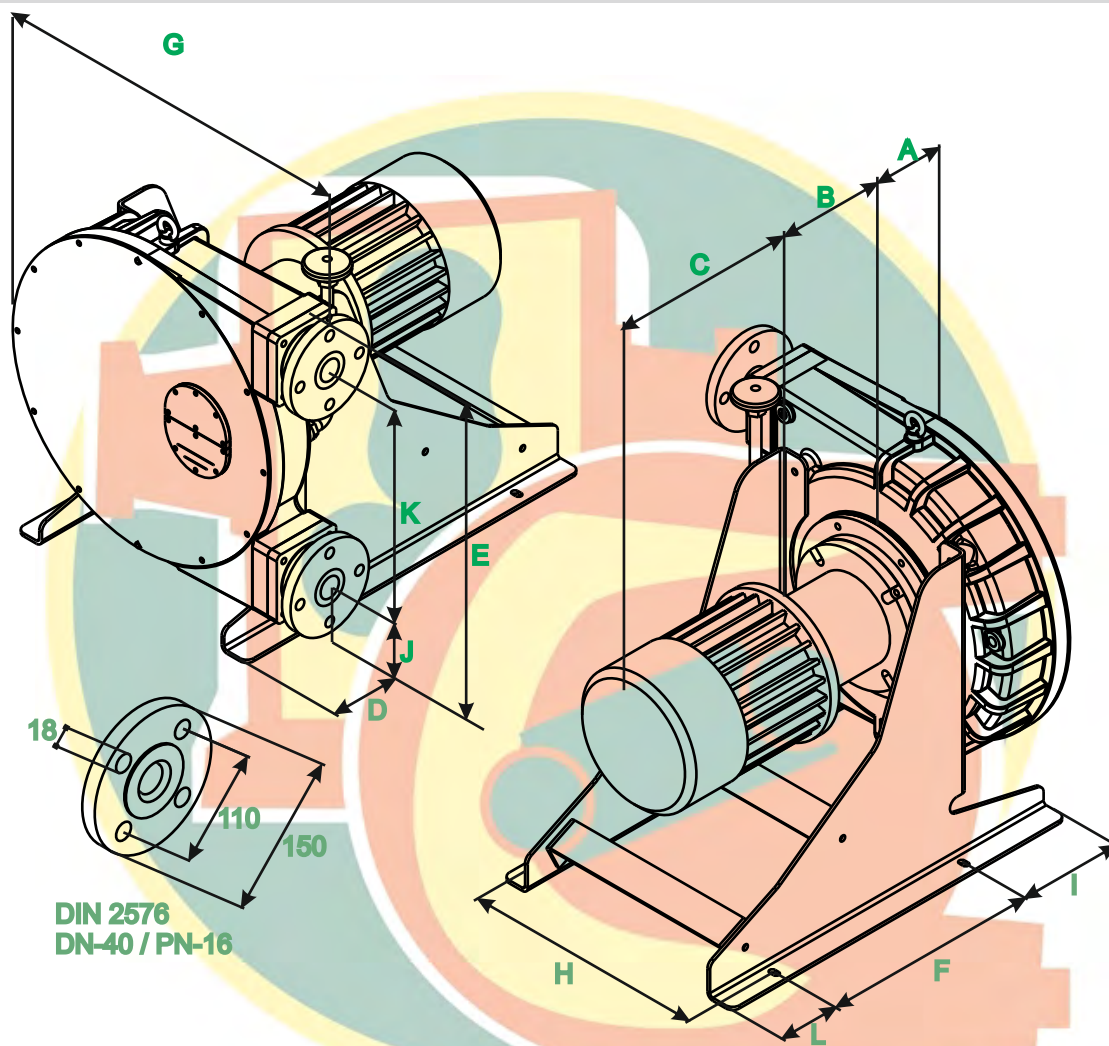

A	B	C	D	E	F	G	H	I	J	K	L
151	•	•	79	645	415	633	456	200	159	412	115

\* To confirm according type and power driver.

