

Industrial Peristaltic Pumps

RBT-80 Data sheet

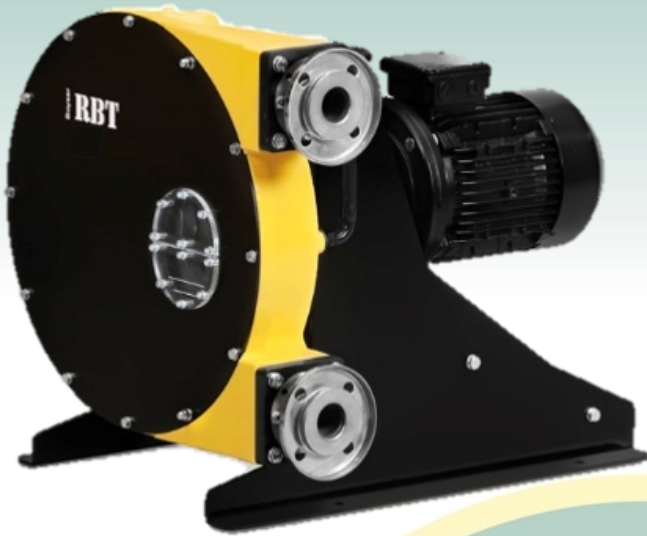

Capacity:	11,7 l/rev.
Connections:	DN-80
Max. Pressure:	15 bar
Rotor system:	Shoes
Available hoses:	NR NBR EPDM HYPALON

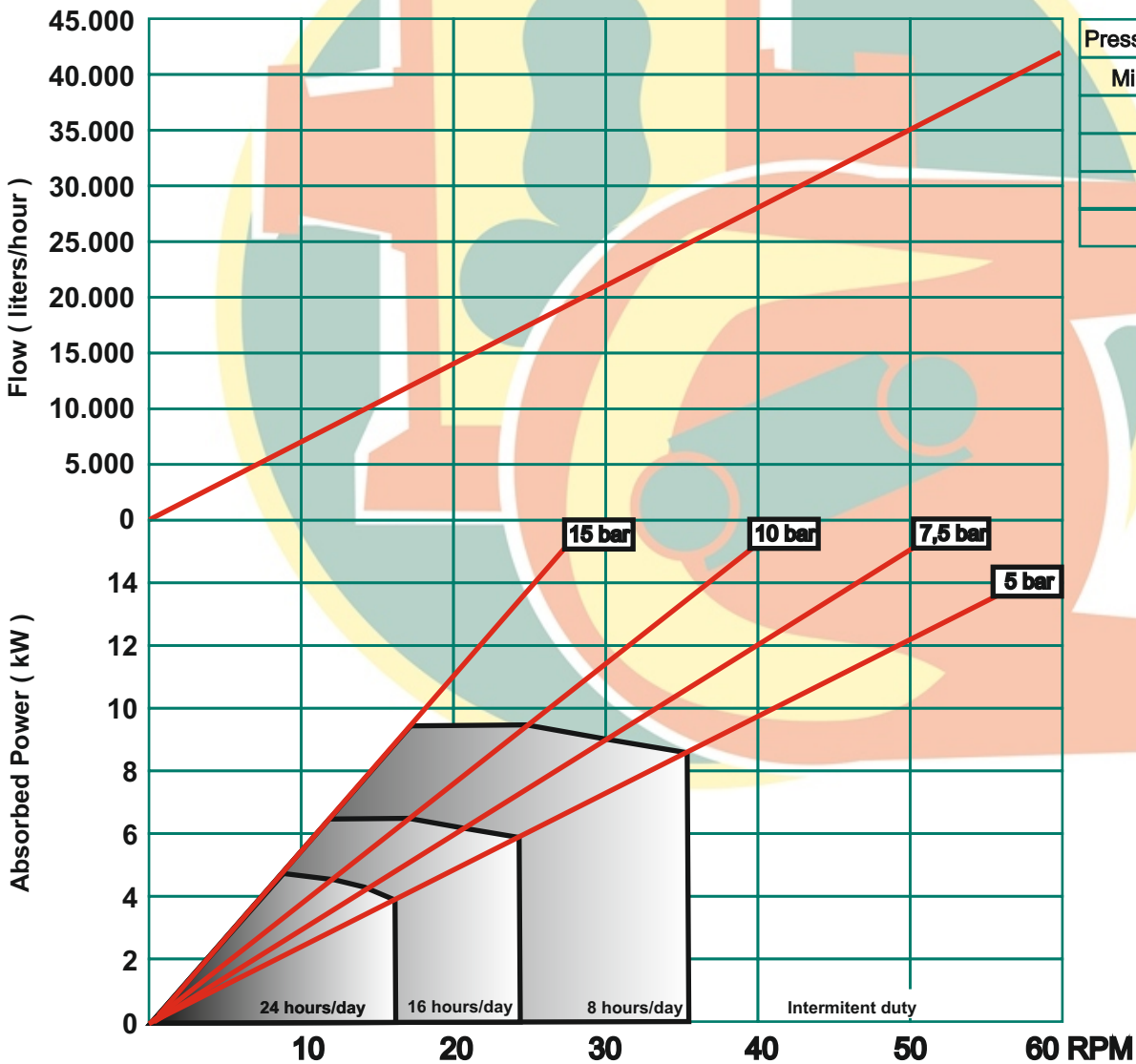

Pressure (bar)	Torque (Nm)
Minimum	1700
5	2300
7,5	2900
10	3700
15	5200



Description	Material	Surface treatment
Pump housing	Cast Iron EN-GJL-250	Polyester powder coated Halar coated (Optional)
Front cover	Steel F-111 / Methacrilate	Polyester powder coated Halar coated (Optional)
Rotor	Nodular Cast Iron EN-GJL-400	Cataforesis
Shoes	Nodular Cast Iron EN-GJL-400	Hardened
Base plate	Steel F-111 Stainless Steel AISI-304 (Optional)	Polyester powder coated --
Connections	Stainless Steel AISI-316 Polypropylene (Optional) PVDF (Optional)	--

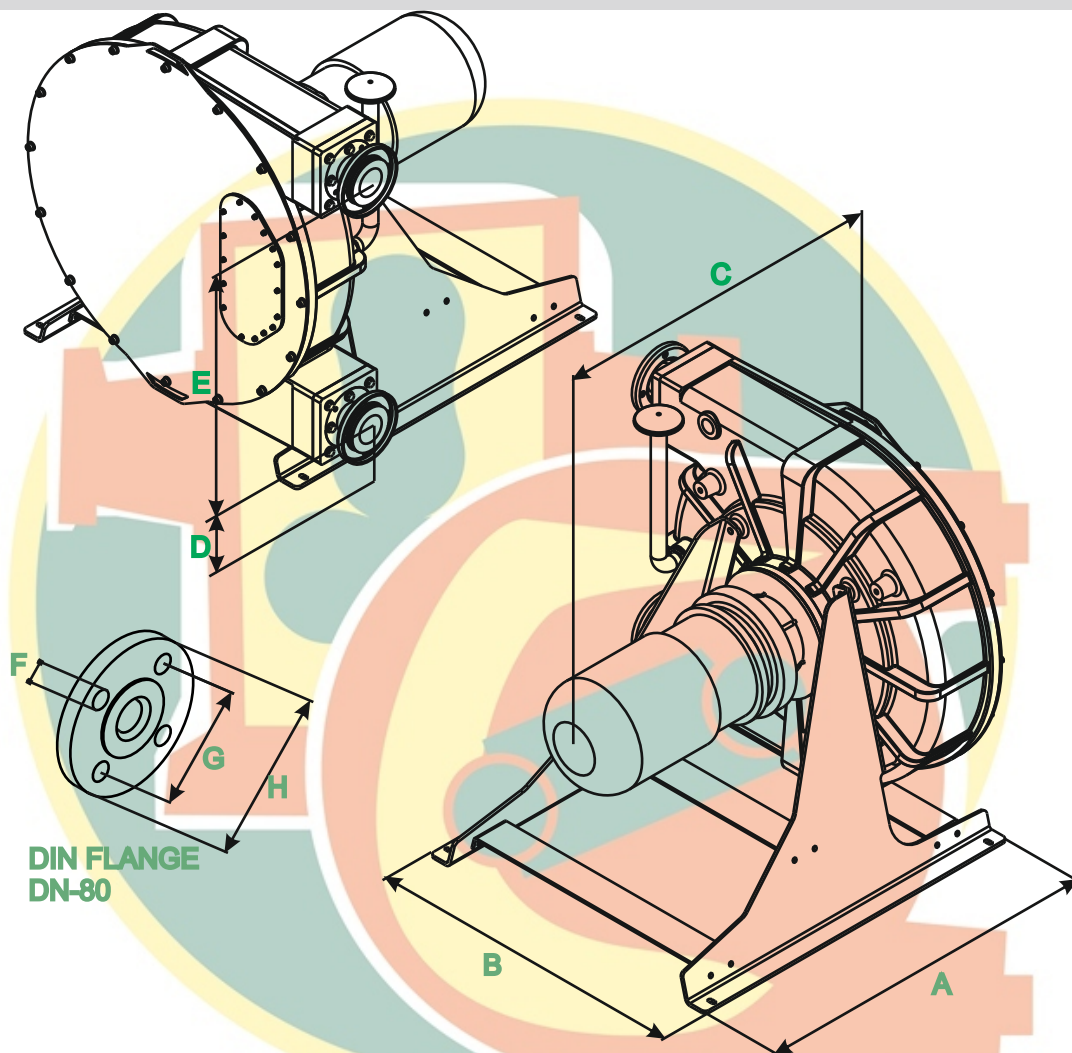

**DIN FLANGE
DN-80**

A	B	C	D	E	F	G	H
1200	1093	1150 *	205	850	17,5	160	200

* To confirm according type and power driver.

