

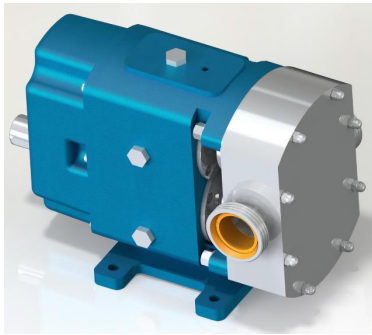

GQT 2" Rotary Lobe Pump



Performance:

Flow rate	18 m ³ /h
Pressure	1 - 8 bar
Temperature	0 - 150 °C
Speed	1 - 500 d/d
Viscosity	150 - 250000 SSU

- 2" Standard Port Size
- 2½" Enlarged Port Size

Technical Features:

- ✓ Rotary lobe pump
- ✓ 2" threaded ports
- ✓ Suitable for hygienic applications involving food
- ✓ Good clean in place qualities
- ✓ Gentle, low pulsation pumping mechanism
- ✓ Compact design
- ✓ Various material options
- ✓ Various sealing options
- ✓ Available with sanitary clamp connection and heating jacket
- ✓ Motor or gearbox drive available
- ✓ 230v, three phase 50/60hz motors available
- ✓ Manufactured according to CE regulations

Applications:

- ✓ Sanitary and hygienic applications
- ✓ Shear sensitive products
- ✓ Food processing
- ✓ Pharmaceutical
- ✓ Chemical
- ✓ Paper and pulp
- ✓ Gels and greases
- ✓ Paint and dyes

Material Options:

- ✓ Pump body & cover: Cast iron
- ✓ Lobe casing & lobes: Steel cast, stainless AISI 304 / 316
- ✓ Bearings: Bearing
- ✓ Sealing: Mechanical seal, lip seal

Capacity & Power Table

Capacity	Speed (rpm)	Pressure			Viscosity
		0 Bar	3.5 Bar	7 Bar	
3.6	100	2 HP	3 HP	4 HP	75000 SSU
7.2	200	3 HP	5.5 HP	7.5 HP	75000 SSU
11	300	3 HP	5.5 HP	7.5 HP	15000 SSU
14.5	400	3 HP	5.5 HP	7.5 HP	2500 SSU
18.3	500	3 HP	5.5 HP	7.5 HP	500 SSU
19.3	550	3 HP	5.5 HP	7.5 HP	150 SSU



Pump Dimensions:

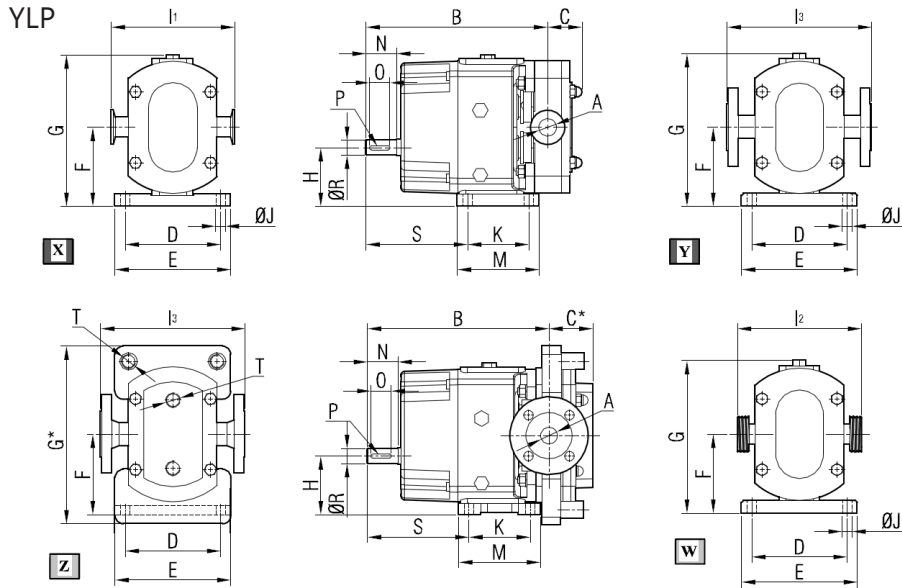

X	Pump with Sanitary Clamp Connection
Y	Pump with Flange Connection
Z	Pump with Heating Jackets
W	Pump with Male Thread Connection
B	For Pump with Code 001
B*	For Pump with Code 002

Pump Code	A	B	B*	C	C*	D	E	F	G	G*	H	I ₁	I ₂	I ₃	J	K	M	N	O	P	R	S	T	kg
YLP4 062	DN50	374	389	63	74	180	220	152	295	336	104	218	245	294	14	140	180	47	40	10x8	38	180	½"	74
	DN65											293	300	300										75

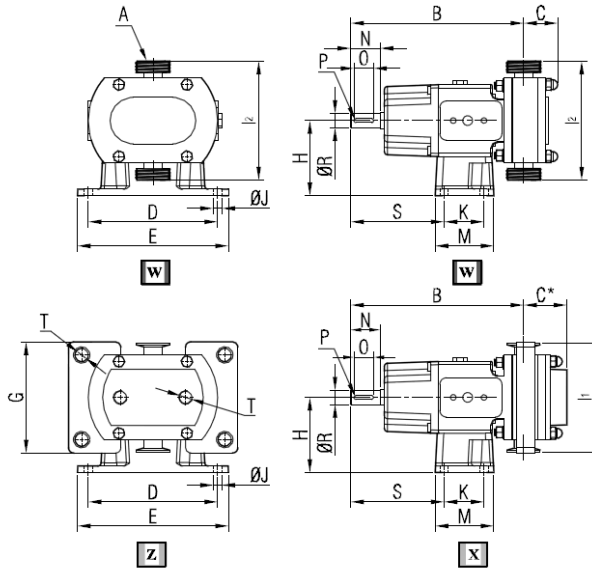

X	Pump with Sanitary Clamp Connection
Z	Pump with Heating Jackets
W	Pump with Male Thread Connection
B	For Pump with Code 001
B*	For Pump with Code 002

Pump Code	A	B	B*	C	C*	D	E	G	H	I ₁	I ₂	J	K	M	N	O	P	R	S	T	kg	
YLP2 062	DN50	374	389	63	74	248	280	231	157	218	245	13	123	153	47	40	10x8	38	158	½"	72	
	DN65									293	300											



Coupling Dimensions - Gearbox Drive::

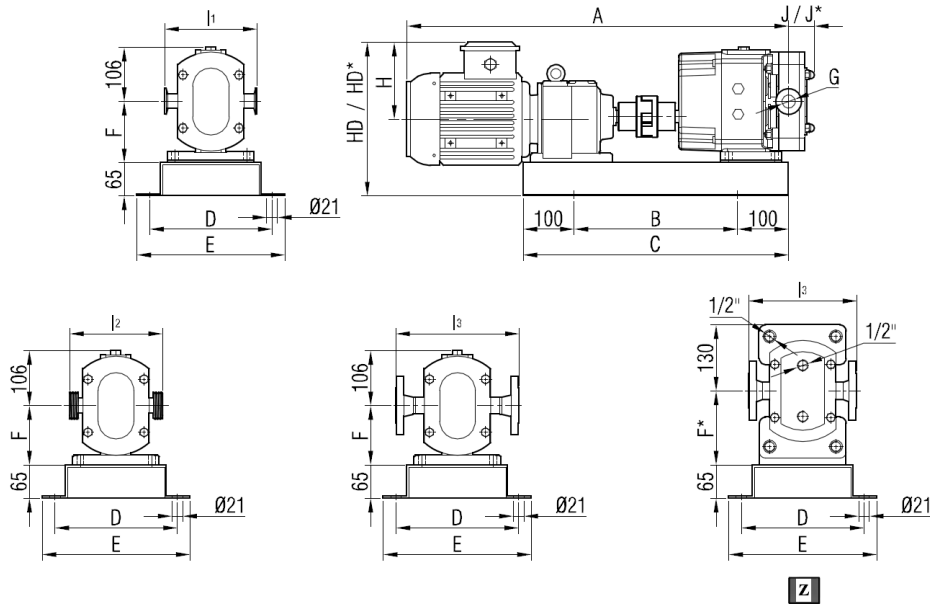

***Add 25 mm to A dimension for 002 type pump.

Pump Code	G	I ₁	I ₂	I ₃	J	J*	
YLP4	062	DN50	218	245	294	63	74
001		DN65	293	300	300		

I ₁	Pump with Sanitary Clamp Connection
I ₂	Pump with Male Thread Connection
I ₃	Pump with Flange Connection
Z / HD* / F* / J*	Pump with Heating Jackets

Motor Power & Speed	A	HD	HD*	H	B	C	D	E	F	F*	Kg
4 hp / 3 kw	984	310	335	141	500	700	310	350	163	188	147
77/98 d/d (rpm) IRAM63/100L											
4 hp / 3 kw	1032	330	330	149	550	750	310	350	188	213	163
45/95 d/d (rpm) IRAM73/100L											
5.5 hp / 4 kw	1051	338	338	149	550	750	310	350	188	213	170
55/95 d/d (rpm) IRAM73/112M											
5.5 hp / 4 kw	1010	318	343	149	500	700	310	350	163	188	149
104/500 d/d (rpm) IRAM62/112M											
7.5 hp / 5.5 kw	1098	371	371	182	550	750	310	350	188	213	183
75/230 d/d (rpm) IRAM73/132S											
7.5 hp / 5.5 kw	1010	318	343	149	500	700	310	350	163	188	164
216/480 d/d (rpm) IRAM62/132S											
7.5 hp / 5.5 kw	1213	403	403	182	700	900	380	420	228	253	231
43/91 d/d (rpm) IRAM83/132S											
10 hp / 7.5 kw	1143	314	314	182	550	750	310	350	188	213	192
130/400 d/d (rpm) IRAM72/132M											
15 hp / 11 kw	1329	446	446	225	700	900	380	420	228	253	306
230/460 d/d (rpm) IRAM72/C132M											
15 hp / 11 kw											
106/230 d/d (rpm) IRAM82/160M											



Coupling Dimensions - Gearbox Drive::

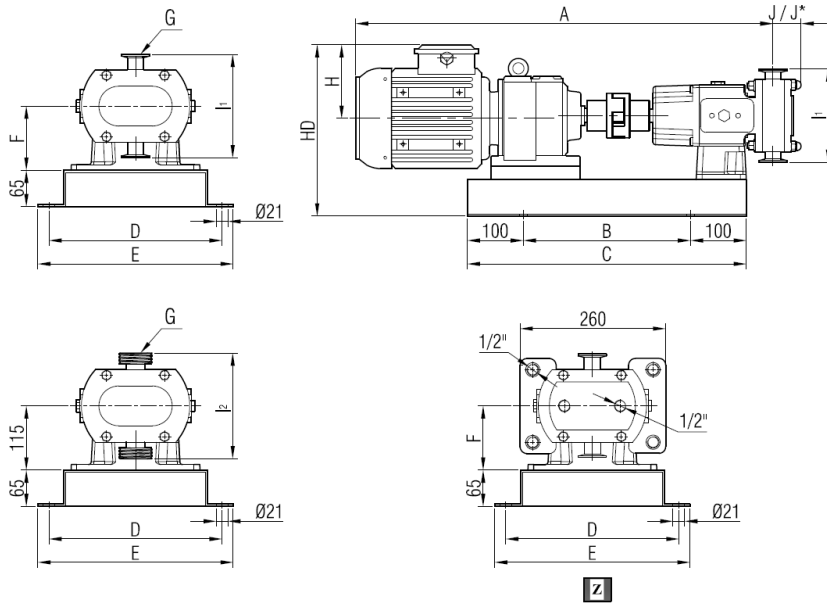

***Add 25 mm to A dimension for 002 type pump.

Pump Code	G	I ₁	I ₂	J	J*
YLP4	062	DN50	218	245	63
001		DN65	293	300	

I ₁	Pump with Sanitary Clamp Connection
I ₂	Pump with Male Thread Connection
Z / J*	Pump with Heating Jackets

Motor Power & Speed	A	HD	H	B	C	D	E	F	Kg
4 hp / 3 kw	984	352	141	430	630				147
77/98 d/d (rpm) IRAM63/100L									161
4 hp / 3 kw	1032	347		500	700				168
45/95 d/d (rpm) IRAM73/100L									149
5.5 hp / 4 kw	1051	355	149			390	430	157	149
55/95 d/d (rpm) IRAM73/112M									181
5.5 hp / 4 kw	1010	360	149	430	630				164
104/500 d/d (rpm) IRAM62/112M									182
7.5 hp / 5.5 kw	1098	420	182	500	700				190
75/230 d/d (rpm) IRAM52/90L									164
7.5 hp / 5.5 kw	1010	360	149	430	630				223
216/480 d/d (rpm) IRAM62/132S									182
7.5 hp / 5.5 kw	1213	404		610	810	420	460	180	190
43/91 d/d (rpm) IRAM83/132S									192
10 hp / 7.5 kw	1143	420	182	500	700	390	430	157	192
130/400 d/d (rpm) IRAM72/132M									298
15 hp / 11 kw	1329	447	225	610	810	420	460	180	192
230/460 d/d (rpm) IRAM72/C132M									298
15 hp / 11 kw	1329	447	225	610	810	420	460	180	298
106/230 d/d (rpm) IRAM82/160M									298



Spare Parts List:

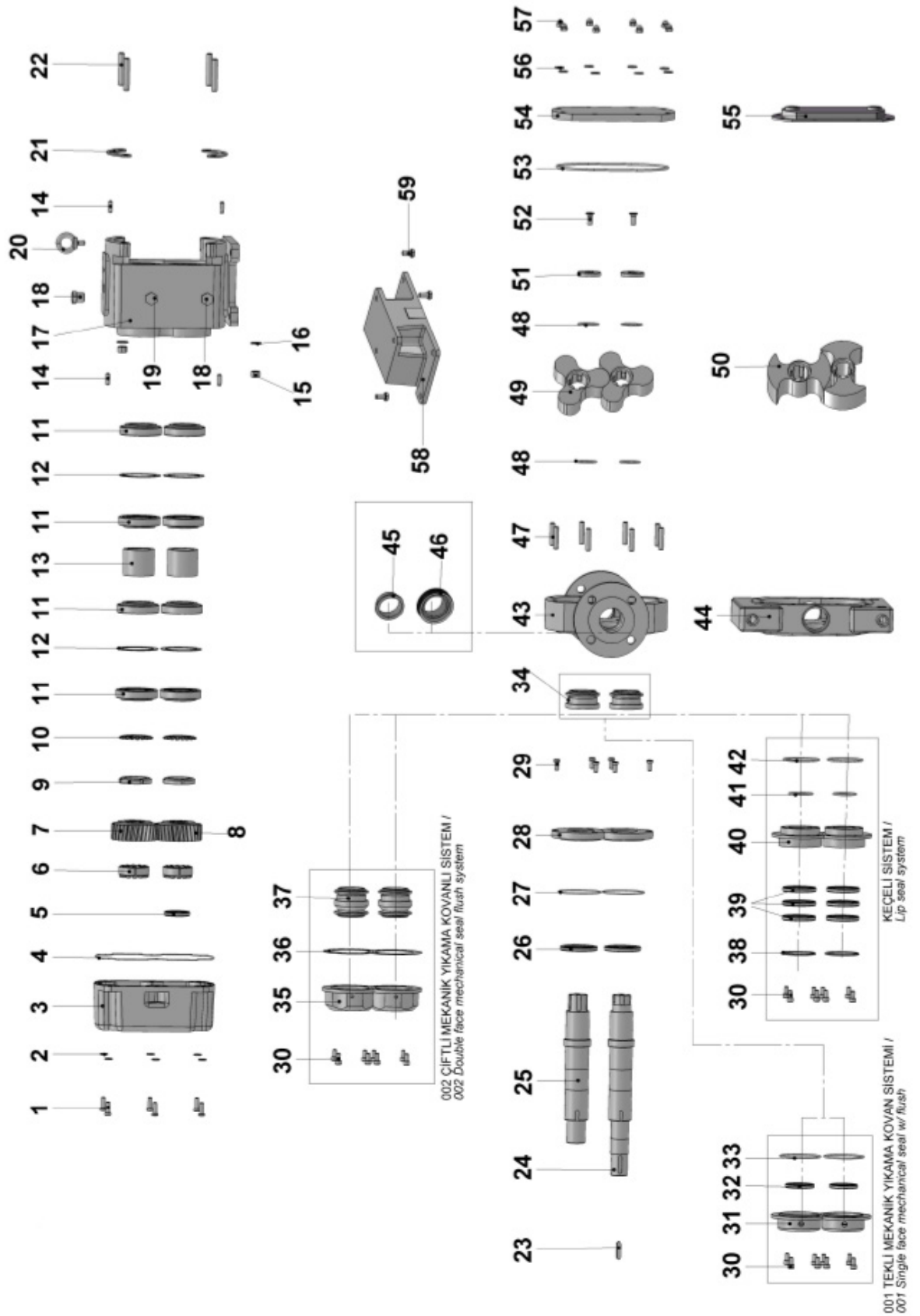



No.	Part Name.	Qty.
1	Hex Socket M8x35	6
2	M8 Washer	6
3	Back Cover	1
4	Back Cover O-Ring	1
5	Lip Seal $\varnothing 40 \times \varnothing 56 \times 8$	1
6	Squeezer (CTL-200-040)	2
7	Right Helical Gear	1
8	Left Helical Gear	1
9	Lock Nut M50x1.5	2
10	Lock Washer M50	2
11	Bearing 30210	8
12	Bearing Spacer Sheet Material	4
13	Spacer	2
14	Pin $\varnothing 8 \times 25$	4
15	M12 Nut	4
16	M12 Washer	4
17	Casing	1
18	Caps R1/2"	2
19	Oil Indicator R1/2"	1
20	Eyebolt	1
21	Adjusting Plate	2
22	Studbolt M12x70	4
23	Coupling Key 10x8x40 A	1
24	Driving Shaft	1
25	Driven Shaft	1
26	Lip Seal $\varnothing 58 \times \varnothing 80 \times 8$	2
27	Bearing Cover O-Ring	2
28	Bearing Cover	2
29	Hex Socket M8x20	6
30	Hex Socket M6x20	24

No.	Part Name.	Qty.
31	Flush of Single Face Mechanical Seal	2
32	Lip Seal $\varnothing 50 \times \varnothing 62 \times 7$	2
33	Flush O-Ring	2
34	Single Face Mechanical Seal	2
35	Flush of Double Face Mechanical Seal	2
36	Flush Casing of Double Face Mechanical Seal	2
37	Double Face Mechanical Seal	2
38	Internal Circlip ($\varnothing 72$)	2
39	Lip Seal $\varnothing 50 \times \varnothing 72 \times 8$	6
40	Flush of Lip Seal	2
41	Outer O-Ring of Lip Seal Housing	2
42	Front Face O-Ring of Lip Seal Housing	2
43	Lobe Casing	1
44	Jacketed Lobe Casing	1
45	Ferrule	2
46	Rakor	2
47	Studbolt M10x55	8
48	Lobe O-Ring	4
49	Tri-Lobe	2
50	Bi-Lobe	2
51	Lobe Fastener	2
52	Countersunk Head Screws M10x25	2
53	Casing O-Ring	1
54	Front Cover	1
55	Cover (w/ Heating Jacket)	1
56	M10 Washer	8
57	M10 Domed Cap Nut	8
58	Horizontal Pump Foot	1
59	Hex Bolt M10x20	3