



Liverani FEP Flexible Impeller Pump

Close coupled, electrically driven



Performance:

Flow rate	Up to 44 m ³ /h
Pressure	Up to 32 M
Temperature	Up to 100 °C
Viscosity	Up to 50,000 cP
Outlet Sizes	DN 20 up to DN 100 mm

The FEP range of close coupled stainless steel flexible impeller pumps is the most popular within the Liverani range due to its compact and versatile design. They are widely used in transferring, filling & emptying applications but when used in conjunction with a carrying handle and their integral on / off / reversing switch they can also be used as a very reliable utility pump.

NOTE: MINI & MIDEX units are supplied with BSP M connections & SS316 as standard. MINOR, MAJOR & MAXI units are supplied with Garolla connections & SS304 as standard with hose fittings, clamps and seals included, SS316 optional.

Applications:

- ✓ Transferring delicate, fragile and shear sensitive fluids
- ✓ Suitable for viscous fluids with solids in suspension
- ✓ Hygienic/sanitary applications
- ✓ Oenological (wine, must, stemmed grapes)
- ✓ Food processing (fruit pulp, honey, milk, yoghurt, liquid eggs, oil, tomatoes, brine)
- ✓ Chemical (starch, water based glues, paints, ink)
- ✓ Cosmetic and pharmaceutical (liquid soap, shampoo, moisturiser, cleaning products)

Performance:

TYPE	WGT Kg	MOTOR	HP	K.W.	NO. SPEEDS	SPEED RPM	DIFFERENTIAL HEAD (M)									
							0	4	8	12	16	18	24	27	30	32
FEP MINI ¾"	9.3	MF-TF	0.5	0.37	1	900	1000	900	840	720	540	450	0			
	9		0.75	0.56	1	1400	1620	1440	1320	1140	1020	900	600	400	180	0
	10	CC 12-24V	0.4	0.3	1	1400	1620	1440	1320	1140	1020	900	600	400	180	0
FEP MIDEX 1¼"	15	MF-TF	0.75	0.56	1	900	3840	3480	3180	2760	2160	1800	720	0		
			1	0.75	1	1400	5760	5160	4800	4320	3600	3180	1920	1200	0	
		TF	0.75	0.56	2	1400	5760	5160	4800	4320	3600	2180	1920	1200	0	
			0.5	0.37		700	2880	2600	2300	1900	1400	1100	0			
	15.4	CC 24V	0.7	0.5	1	900	3840	3480	3180	2760	2160	1800	720	0		
FEP MINOR 40	20	MF-TF	2	1.5	1	900	6900	6200	5760	5040	4200	3660	1800	0		
			2	1.5	1	1400	10000	9000	8000	6900	5500	4900	2600	1700	0	
	27	TF	2.5	1.87	2	1400	10000	9000	8000	6900	5500	4900	2600	1700	0	
			1.82	1.32		900	6900	6200	5760	5040	4200	3660	1800	0		
FEP MAJOR 60	31	TF	1.7	1.25	1	470	12000	10500	8700	5100	0					
			2	1.5	1	700	18000	15000	12000	8400	2500	0				
			2.5	1.87	1	900	22500	19560	15000	11220	3000	0				
FEP MAXI 80	68	TF	4.5	3.3	1	470	36000	34200	30000	24000	12000	0				
			4.7	3.5	1	600	43800	41400	36000	30000	16000	0				

CAPACITY (L/HOUR)



PERFORMANCE NOTES:

Capacity details are based on WATER
Head is DIFFERENTIAL, therefore suction lift needs to be added to the delivery head

MF = Single Phase
TF = Three Phase
CC = Continuous Current (DC)
110V available on request

MF & TF units supplied with On / Off / Reversing Switches as standard
MF units supplied with 2 m Cable + Schuko Plug
TF units supplied with 4 m Cable, no plug
CC units supplied with Terminal Board Connections for the motor

MINI & MIDEX supplied with BSP M Connections as standard
MINOR, MAJOR & MAXI supplied with Garolla Connections as standard

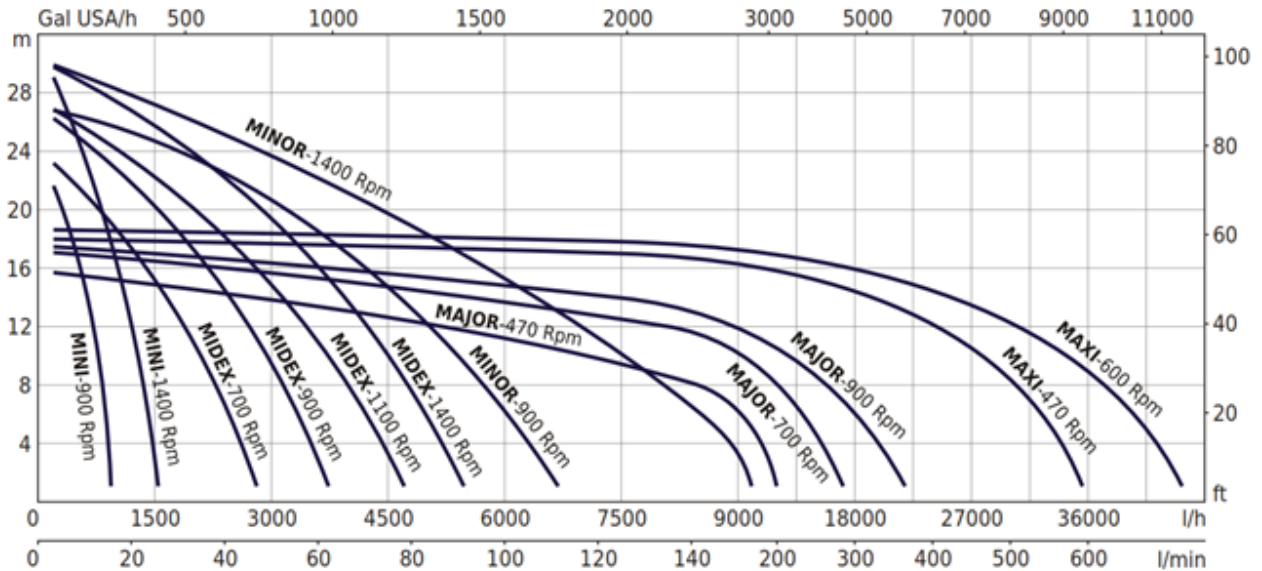

Dimensions Table:

TYPE	MOTOR	1NO. SPEEDS	A	B	E	F	G	H	I1**	I2**	L	M	K	X
FEP MINI ¾"	M71	1	112	90	106	26	71	140	192	210	276	0	7	12
FEP MIDEX 1¼"	M80	1	125	100	148	38	80	159	200	227	338	7	8	16
	M80	2	125	100	148	38	80	159	-	227	338	7	8	16
FEP MINOR 40	M90	1	140	125	198	60	90	180	210	240	420	4.5	10	16
	M100	2	160	140	210	60	100	198	-	260	455	4.5	12	21
FEP MAJOR 60	M100	1	160	140	253	70	100	198	245	263	490	6.5	12	21
	M112	1	190	140	259	70	112	225	275	-	514	6.5	12	22
FEP MAXI 80	M132	1	216	178	312	90	132	261	320	-	630	13	12	22

NOTES:

- * Pipe Fittings available on request
- ** I1 = Motor with Terminal Board Connections
- ** I2 = Motor with On / Off / Reversing Switch

Pump can be ordered with the connections facing in the position required (V, 90D, 90S). Must be mentioned at order stage.

Pump Heads are SS304 as standard for MINOR, MAJOR & MAXI (SS316 for MINI & MIDEX). SS 316 available on request.

Connections are Garolla as standard for MINOR, MAJOR & MAXI (BSP M for MINI & MIDEX). Others available on request.

Manual by-passes (MINI, MAJOR & MAXI) for manual adjustment of the pump capacity available on request. In order to retain the self-priming capability of the pump the by-pass must be completely closed on initial start-up.

Spring loaded by-pass for the MINOR for manual adjustment of the pump capacity as well as operation with a nozzle.

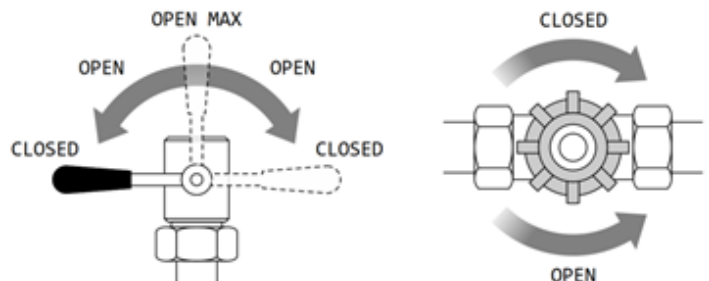



Liverani Flexible Impeller Pumps

Stainless steel, reversible, low-speed rotary pumps with flexible impellers

Applications:

- ✓ Transferring delicate, fragile and shear sensitive fluids
- ✓ Suitable for viscous fluids with solids in suspension
- ✓ Hygienic/sanitary applications
- ✓ Oenological (wine, must, stemmed grapes)
- ✓ Food processing (fruit pulp, honey, milk, yoghurt, liquid eggs, oil, tomatoes, brine)
- ✓ Chemical (starch, water based glues, paints, ink)
- ✓ Cosmetic and pharmaceutical (liquid soap, shampoo, moisturiser, cleaning products)



Transferring



Filling



Emptying



Recycling
& Mixing



Filtering
& Separation



Metering
& Dosing

Operation Benefits:

The vanes of the impeller deform slightly when rotating inside the pump casing, moving the fluid from the inlet to the outlet at a steady, pulseless flow without pressure spikes. This principle combined with a gentle pumping action and a high self-priming capability, up to 6 m from dry, makes these units ideal for transfer, filling, dosing and filtration applications.

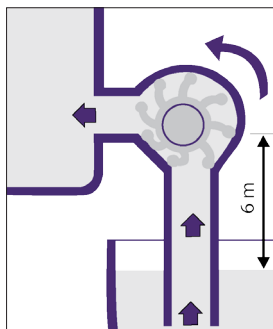

1. Extremely good self-priming ability:

Up to 6 m from dry, enables the evacuation of sumps, tanks, drums & IBCs without the need for a non-return valve or manual priming on installation.

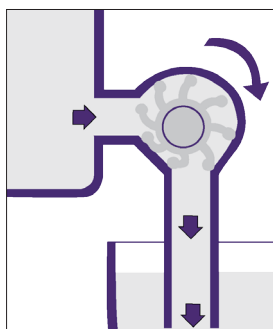

2. Reversible operation:

The pump can operate in both directions of rotation, which permits the return of excess liquid without any manual intervention, and also allows easy emptying of pipes on completion of the liquid transfer. This is particularly useful when emptying tanks for cleaning purposes and refilling afterwards at the flip of a switch.

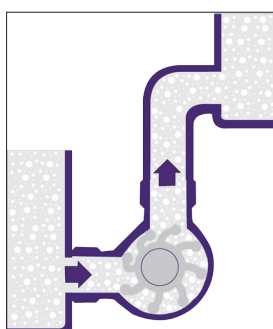

3. Efficiency even at low operating speeds:

This allows the transfer of soft and fragile fluids with viscosities up to 50,000 cPs, or with solid particles in suspension, without causing air-locking, avoiding emulsifying or damaging particles. This makes these units ideally suited for shear sensitive fluids.

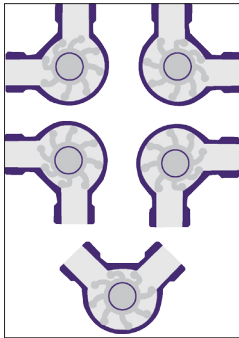

4. The pump can work in all mounting positions:

The casing can be rotated through 5 different positions enabling the pump to be installed into various pipework configurations enabling the customer to make the pump work for their system and not alter the system to fit the pump.

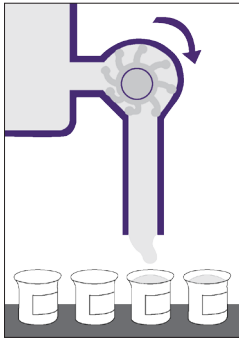

5. Smooth steady pumping action of the product without pressure spikes:

Provides an even flow rate ideal for filling, dosing or filtration applications. The Midex and Minor pumps can be fitted with spring loaded by-passes to enable operation with nozzles or delivery valves to protect the pumps against "dead head" operation.

6. The easy mounting principle, the multiple choices of production materials provides a wide, versatile and customisable product range. Every pump range can be produced with different impeller types, sealing options, couplings / connections, numerous executions, with or without control panels and remote controls. A wide range of accessories are also available.

Exploded View & Build Options:

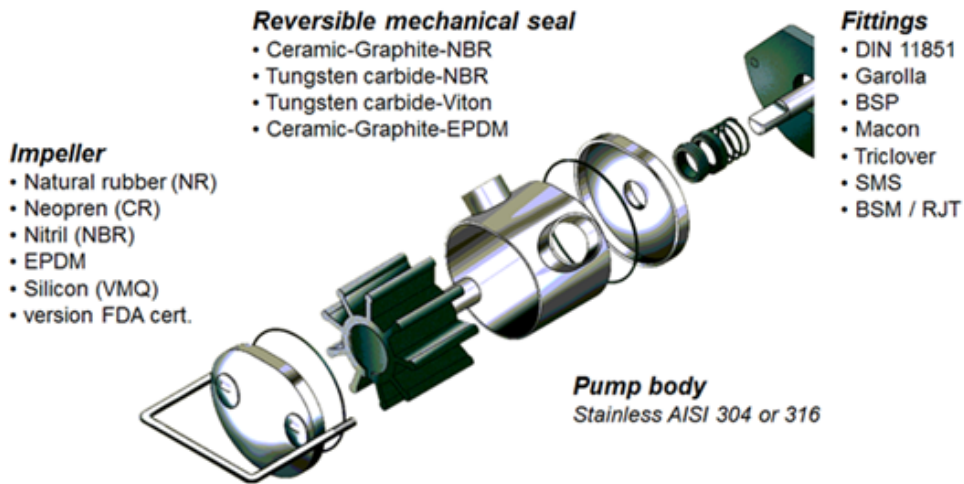

Impeller Features:

- ✓ Natural rubber (NR): Excellent for water based liquid at room temperature, highest mechanical resistance.
- ✓ Neoprene (CR): Good balance between chemical and mechanical resistance.
- ✓ Nitrile (NBR): Excellent resistance to oils and fats.
- ✓ EPDM: Best for hot fluid and CIP cleaning. Excellent for acid and alkaline fluids.
- ✓ Silicon (VMQ): Best for high temperature but low mechanical resistance.

NOTE: All impellers are food grade however only EPDM & NBR are able to be supplied with FDA Certification.



Nitrile
Nitrile



Neoprene
Neoprene rubber



EPDM
EPDM



Gomma naturale
Natural rubber



Silicone
Silicon



Impeller Corrosion Table:

Temperatures listed are the highest temperatures that can be used. 20°C corresponds to average room temperature.

The term "Variable / V" means that within the same family of polymers there can be different behaviours according to the kind of polymer, the concentration of the product and the temperature at which it is used.

KEY	A	B	C	V	ND
	Excellent	Fair / Good	Not Advisable	Variable	No Data

PRODUCT	NBR	EPDM	CR	NR	VQM
Acetic Acid (30%)	B (20°C)	A	B (20°C)	B (20°C)	ND
Ammonium Hydroxide (30%)	A (80°C)	ND	A (90°C)	A (65°C)	ND
Aniline	C	A (90°C)	C	C	B (20°C)
Aniline Oil	C	B (20°C)	C	C	C
Beer	A (60°C) - B (80°C)	A (60°C) - B (80°C)	A (60°C)	A (20°C)	A (20°C)
Benzyl Alcohol	C	B (40°C) - C (60°C)	V	C	ND
Boric Acid	A (60°C) - B (90°C)	A (60°C) - B (90°C)	A (70°C) - B (90°C)	A (20°C) - B (85°C)	A (20°C)
Bromic Acid (40%)	C	A (90°C)	V	B (20°C)	C
Butadiene	V	V	V	C	C
Butane	A (90°C) B (80°C)	C	A (60°C)	C	C
Butter	A (60°C)	A (60°C)	B (20°C) - C (60°C)	C	B (20°C)
Calcium Hydrate	A (90°C) - B (90°C)	A (20°C)	A (20°C) - B (90°C)	A (20°C) - B (65°C)	A (20°C)
Calcium Hypochlorite	C	A (120°C)	C	C	B (20°C)
Cane Sugar Liquid	A (20°C) - B (90°C)	A (80°C)	A (20°C) - B (90°C)	A (20°C)	A (20°C)
Castor Oil	A (70°C)	A (60°C)	A (70°C)	A (25°C)	A (20°C)
Chlorine (Dump)	C	V	C	C	C
Chloroacetic Acid	C	B (70-90°C)	A (20°C) - C (40°C)	V	V
Chloroform	C	C	C	C	C
Chromic Acid	C	B	V	V	V
Citric Acid	A (70°C) - B (80°C)	A	A	A (20°C)	A (20°C)
Cod-Liver Oil	A (20°C) - B (50°C)	A (20°C)	B (20°C)	C	B (20°C)
Corn Oil	A (80°C)	V	B (20°C)	C	A (20°C)
Cotton Oil	A (70°C) - B (80°C)	A (20°C) - C (80°C)	B (65°C)	C	A (20°C)
Diesel Oil	A (80°C)	C	C	C	C
Ethyl Acetate	C	A (55°C) - C (70°C)	C	C	B (20°C)
Ethyl Alcohol	A (60°C) - B (85°C)	A (90°C)	A (70°C) - B (80°C)	A (20°C) - B (65°C)	B (20°C)
Fluoboric Acid	A (60°C) - B (85°C)	A (60°C) - B (80°C)	A (60°C) - B (85°C)	A (20°C) - B (65°C)	A (20°C)
Formic Acid	V	A (90°C)	V	B (20°C)	B (20°C)
Fruit Juices	A (60°C)	A (100°C)	A (60°C)	V	A (20°C)
Gelatine	A (70°C)	A (80°C)	A (60°C) - B (80°C)	A (20°C) - B (65°C)	A (20°C)
Glucose	A (70°C)	A (80°C)	A (60°C)	A (20°C) - B (48°C)	A (20°C)
Glycerine	A (80°C)	A (80°C) - B (90°C)	A (70°C)	A (20°C) - B (65°C)	A (20°C)
Hydraulic Oil	C	A (100°C)	C	C	V
Hydrochloric Acid (Conc.)	C	C	C	V	C
Hydrocyanic Acid	B (60°C)	A (60°C)	V	ND	B (20°C)
Hydrofluoric Acid (50%)	C	B (60°C)	V	C (20°C)	V
Hydrofluoric Acid (Conc.)	C	C	C	C	C
Iodine	B (60°C)				
A (20°C), 6.5%	B (70°C)				
A (20°C), 6.5%	C	C	C		













Kerosene	A (80°C)	C	B (20°C)	C	C
Lactic Acid (Conc.)	A (20°C)	A (60°C)	A (20°C) - B (60°C)		
C (80°C)	ND	ND			
Linseed Oil	A (80°C)	B (20°C)	B (20°C)	C	C
Magnesium Chloride	A (70°C) - B (80°C)	A (80°C) - B (100°C)	A (80°C) - B (90°C)	A (20°C) - B (85°C)	A (20°C)
Magnesium Sulphate	A (80°C) - B (100°C)	A (80°C) - B (100°C)	A (80°C) - B (90°C)	B (85°C)	A (20°C)
Mercury	A (60°C)	A (60°C)	A (60°C)	A (20°C)	A (20°C)
Methyl Alcohol	B (65°C)	A (70°C) - B (80°C)	A (60°C) - B (80°C)	B (37°C)	A (70°C)
Methyl-Ethyl-Ketone	C	A (60°C) - B (90°C)	C	C	C
Milk	A (60°C)	A (100°C)	A (60°C)	A (20°C) - B (37°C)	A (20°C)
Nitric Acid (10%)	C	A (40°C) - C (80°C)	C (40°C)	C	B (20°C)
Nitric Acid (70%)	ND	C	C	C	C
Olive Oil	A (80°C)	B (20°C)	V	C	V
Oxalic Acid (Conc.)	B (60°C)	A (100°C)	B (60°C)	B (20°C)	B (20°C)
Palmitic Acid	A (70°C)	B (20°C)	B (20-70°C)	B (20°C)	C
Paraffin	A (60°C)	C	B (20°C)	V	C
Perchloroethylene	V	C	C	C	V
Petrol	A (80°C)	C	C	C	C
Phosphoric Acid (85%)	C	A (80°C)	A (40°C)	B (65°C)	C
Picric Acid	C	A (20°C)	B (20°C)	C	C
Picric Acid (10%)	B (70°C)	B (90°C)	A (20°C) - C (40°C)	B (20°C)	C
Pine Oil	B (80°C)	C	C	C	C
Propyl Alcohol	B (80°C)	B (90°C)	A (60°C) - B (90°C)	A (20°C) - B (65°C)	A (20°C)
SAE Oil N. 10	A (80°C)	C	V	C	V
Sodium Chloride	A (70°C)	B (90°C)	A (80°C)	A (65°C)	B
Sodium Hydrate	B (65°C)	A (20°C)	B (90°C)	A (20°C) - B (65°C)	C (20°C)
Soybean Oil	A (80°C)	V	B (20°C)	C	C
Stearic Acid	A (80°C)	B (60°C)	B (60-70°C)	V	B (20°C)
Sulphur (fused 120°C)	C	A (100°C)	A (20°C)	C (20°C)	A (20°C)
C (120°C)					
Sulphur Dioxide	C	C (20°C)	C (20°C)	C	A (20°C)
Sulphuric Acid (50%)	A (20°C) - C (80°C)	B (60-80°C)	B (70°C)	B (26°C)	V
Sulphuric Acid (80%)	A (20°C) - C (60-80°C)	A (60°C) - C (80°C)	C	C	C
Toluol	C	C	C	C	C
Tomato Juices	A (60°C)	A (80°C)	A (60°C)	ND	ND
Trichloroethylene	C	C	C	C	C
Triethanolamine	C (20°C) 100%				
B (37°C) 80%	A (70°C)	A (70°C)	B (26°C)	C	
Vegetable Oil	A (70°C)	V	C (20°C)	C	A (20°C)
Vinegar	B (20°C) - V (60°C)	A (60-90°C)	B (90°C)	B (20°C)	A (20°C)
Water	A (80°C)	A (100°C)	B (80°C)	A (20°C) - B (80°C)	B (80°C)
Whiskey	A (90°C)	A (90°C)	A (60°C) - C (90°C)	A (20°C) - B (65°C)	A (20°C)
Wine	A (90°C)	A (90°C)	A (90°C)	A (20°C) - B (65°C)	A (20°C)
Xylol	C	C	C	C	C



Impeller Corrosion Table:

Temperatures listed are the highest temperatures that can be used. 20°C corresponds to average room temperature.

The term "Variable / V" means that within the same family of polymers there can be different behaviours according to the kind of polymer, the concentration of the product and the temperature at which it is used.

IMPELLER MATERIAL REFERENCE			PUMP REFERENCE	
		NBR Nitrile Nitrile	MINI ¾"	n.d.
		CR Neoprene Neoprene rubber	MIDEX 1¼"	3173007
		EPDM EPDM EPDM	MINOR 40	3174007
		NR Gomma naturale Natural rubber	MAJOR 60	3176007
		VMQ Silicone Silicon	MAXI 80	3178007



Impeller Corrosion Table:

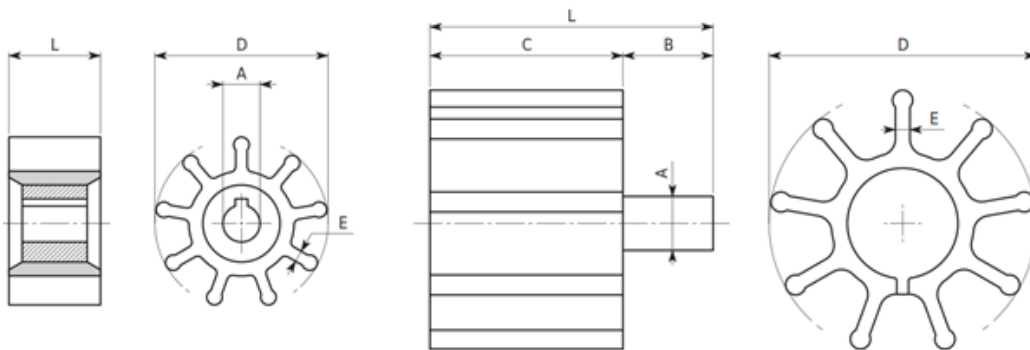

TYPE	A	B	C	D	E	L	NO. BLADES
MINI ¾"	Ø 12	-	29.6	Ø 56	4	29.6	8
MIDEX 1¼"	Ø 24.8	35	52	Ø 66.5	5	87	8
MINOR 40	Ø 24.8	37	87	Ø 98	5.5	124	9
MAJOR 60	Ø 30	40	107	Ø 146	7	167	9
MAXI 80	Ø 30	30	144	Ø 196	10	185	9

Dimensions in mm



Technical Notes on Pump Selection:

Impeller and Seal Compatibility are to be checked thoroughly against the impeller compatibility chart and suitability of SS304 & SS316 to be verified as well.

Performance Curves and Charts show DIFFERENTIAL head (H), therefore, pipe friction loss and suction lift need to be added to the discharge head.

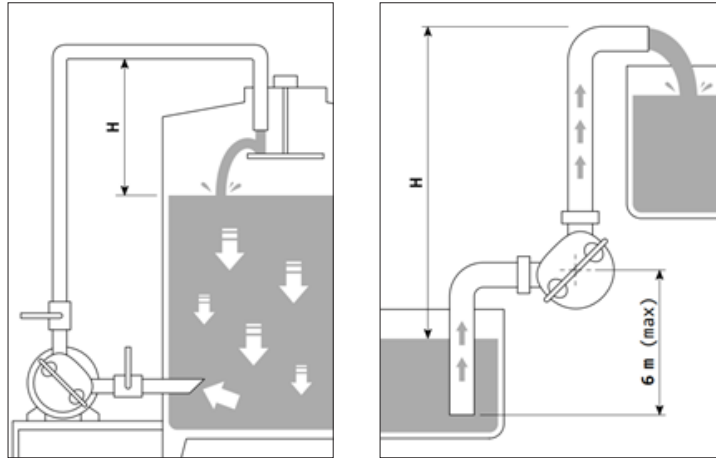

Spring Loaded By-Passes are only available for MIDEX and MINOR units therefore all other units need an external relief when being used with nozzles or on a system where closed valve operation is possible.

As these pumps are reversible, wiring and direction of rotation need to be monitored when installing and operating the pumps.

Viscosity affects the capacity and suction lift capability of pumps, for fluids with a viscosity of approximately 100 cP a 25% loss can be expected. For products with a viscosity of approx. 4000 cP, a 60% loss can be expected. This needs to be taken into account when selecting a suitable model. Furthermore, the operating speed of the pump should also be reviewed as well.

100cP: 900rpm Max

2000cP: 470rpm Max

4000cP: 300rpm Max

For pumps being used on low and high viscosity fluids then 2 speed, mechanically varied or inverter driven pumps are recommended.

Connection Types:

	MINI	MIDEX	MINOR	MAJOR	MAXI
TYPE					
Garolla	Non disponibile Not available	Garolla 40	Garolla 40 Garolla 50	Garolla 50 Garolla 60 Garolla 70	Garolla 70 Garolla 80 Garolla 100
DIN 11851	DIN 20 DIN 25	DIN 32 DIN 40	DIN 40 DIN 50	DIN 50 DIN 60 DIN 65	DIN 65 DIN 80 DIN 100
BSP-M	BSP-M 3/4"	BSP-M 1"1/4	BSP-M 1"1/4 BSP-M 1"1/2	BSP-M 2"	BSP-M 2"1/2 BSP-M 3"
BSP-F	Non disponibile Not available	BSP-F 1"	BSP-F 1" BSP-F 1"1/4	BSP-F 1"1/2 BSP-F 2"	BSP-F 2"1/2 BSP-F 3"
Macon	Non disponibile Not available	Macon 40	Macon 40 Macon 50	Macon 40 Macon 50	Macon 70
Triclover	Triclover 1"	Triclover 1"1/2	Triclover 1"1/2	Triclover 2"	Triclover 3"
SMS	SMS 25	SMS 38	SMS 38	SMS 51	SMS 76
BSM (RJT)	BSM 1"	BSM 1"1/2	BSM 1"1/2	BSM 2" BSM 2"1/2	BSM 3"
Friederich	Non disponibile Not available	Friederich 40	Friederich 40	Friederich 40 Friederich 60	Friederich 60



General Control Panels:



CE Compliant Standard Control Panel

- ✓ Used for simple on / off / reverse control of 1 MF / TF pump
- ✓ IP55 ABS enclosure
- ✓ Supplied with a 6 m cable, no plug
- ✓ Can be supplied loose with mounting fittings or mounted to a trolley handle. Panel has a moulded back for mounting to a 30 mm ø tube or pipe.
- ✓ No volt release feature to protect the pump from automatic start up in case of voltage drop.
- ✓ Cosmetic and pharmaceutical (liquid soap, shampoo, moisturiser, cleaning products)



CE Compliant Control Panel with supplementary 24 NC Shunt Trip for Temperature Sensors, Pressure Switches, Level Sensors etc...

- ✓ Used for more sophisticated control of 1 MF / TF pump.
- ✓ On / Off/ Reversing Function
- ✓ Spare 24V NC Shunt Trip for automating the pump via pressure / temperature transducers / sensors, flow meters, level sensors or for dry run protection.
- ✓ IP55 ABS enclosure
- ✓ Supplied with a 10 m cable, no plug
- ✓ Can be supplied loose with mounting fittings or mounted to a trolley handle. Panel has a moulded back for mounting to a 30 mm ø tube or pipe.
- ✓ No volt release feature to protect the pump from automatic start up in case of voltage drop.



CE Compliant Control Panel with On / Off / Reversing Control and 2 Timer Selector Switches

- ✓ Same features as the Standard CE Control Panel with the addition of 2 Timer Selector switches with 12 possible settings each and 2 pause options. Delay times to be stated with order.

Example:

- ✓ LIVE1 Type = Run 2-24 minutes, pause 10-120 minutes.
- ✓ LIVE2 Type = Run 2-24 minutes, pause 1-12 hours.
- ✓ Supplied with 10 m cable, no plug.
- ✓ Dry Run Protection optional.

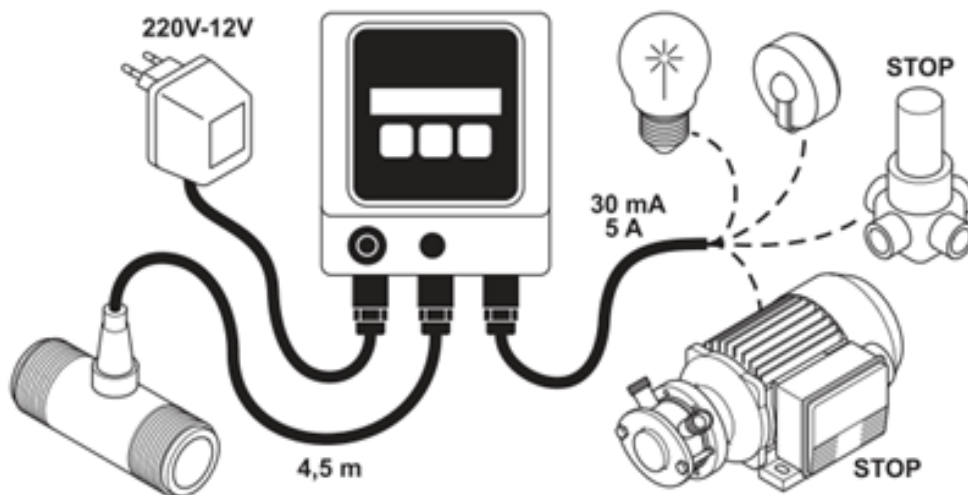



Programmable Litre Counter & Flow Display:

Features the Pony Plus 4 Liquid Measuring & Reading Instrument with timed intermittent output signal, connected to a variety of flow meters to provide real-time display of flow rate and total flow rate achieved. The desired quantity can be set to obtain an output signal (12 VDC 5A) controlled by a programmable timer. This enables a cost effective method of monitoring transfer applications as well as batching from larger bulk carrying tanks such as IBCs to smaller vessels. The output signal generated can be used to stop a pump or close a valve or signal a sounder beacon or light indicator.

The system can be supplied wired and configured for use with the following flow meters according to the line size and capacity range required. NOTE: Max Viscosity the flow meter can handle is 80-100 cPs.

TYPE	INLET / OUTLET	OUTPUT SIGNAL	BODY MATERIAL	MAX PRESSURE	CAPACITY RANGE
PONY PLUS ½"	1"	30 mA / 5 A	Stainless Steel AISI 316	40 Bar	3 - 30 l/min
PONY PLUS ¾"					7 - 70 l/min
PONY PLUS 1"	1¼"				10 - 100 l/min
PONY PLUS 1½"	1½"				35 - 350 l/min
PONY PLUS 2"	2"				7 - 750 l/min
PONY PLUS 2½"	2½"				100 - 1000 l/min
PONY PLUS 3"	3"				150 - 1500 l/min
PONY PLUS 4"	4"				300 - 3000 l/min
PONY PLUS 5"	5"				500 - 5000 l/min

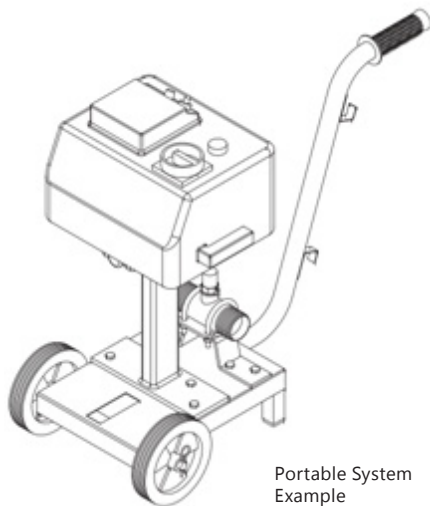

Portable System Example

The system can be supplied as a standalone portable kit for use with external pumps or valves, as shown to the left, or can be supplied as a bespoke system wired and piped to a suitable pump as a drop in solution, as shown in the below example, designed and calibrated to fit the application requirements.

Bespoke System Example:

Trolley Mounted Food Grade Self Priming Side Channel Pump w/ Control Panel, Programmable Litre Counter, Stopping Signal & Flow Meter

Pump Details: EP SENIOR 1½" Stainless Steel Self Priming Side Channel Pump

Control Panel, Litre Counter & Flow Meter Details:

Mounted to Trolley Handle & Wired to Pump & Flow Meter

Single Speed CE Compliant Control Panel

Mains Isolation Switch with Manual Start / Stop

Dry Run Protection

Separate Programmable Litre Counter w/ Set Range of 35 - 350 Litres

Flow Meter: Pony Plus 1½", Shows real-time flow rate and the total flow rate. Automatic Stop via Flow Meter Stopping Signal

Trolley & Discharge Pipe Details:

Stainless Steel AISI 304 Trolley, 2 Wheeled w/ 2 Back Legs

200 mm x 1½" Discharge Pipe Fitted to Pump Outlet housing the Flow Meter, terminating in a 1½" DIN 11851 Connection





Control Panel Mounting:

To reduce packing and transportation charges the handle for the trolleys and the control panels are supplied loose and need mounting according to the following images. The top bracket for the control panel comes with a loop hook for hanging remote controls, if supplied.

If you are not mounting the control panel to a trolley handle then a 30 mm \varnothing tube or pipe is required to enable it to fit into the moulded back of the panel. The groove is fitted with 2 strips of friction paper to assist with keeping the panel from slipping during mounting and operation.

Cable ties are supplied for tidying up cables between the panel and the motor. The panel comes pre-wired to the pump with a standard length sized for fitting the panel to the trolley handle therefore if you need an extended length of cable this needs to be pointed out at the enquiry stage.

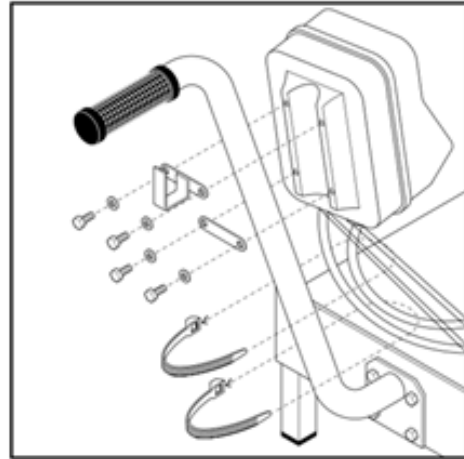
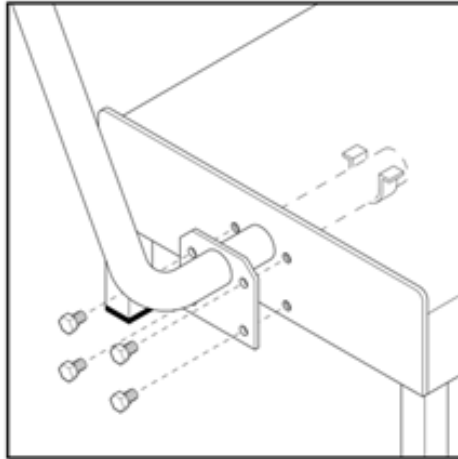

Additional Control Panel information:

1. Reversing switch - The reversing switch is available in a one or two speed configuration.

The single speed version has pos. 0 for standstill mode, whilst the 1 and 2 positions represent the two rotational directions of operation.

The two speed version has two speed positions for each rotational direction:

Pos. 1 represents the lowest speed and pos. 2 the highest. Some pump executions with a single phase motor have a starting reverse switch; in this case the switch must be put on pos AVV and kept in this position until the pump comes into operation. The switch is then released which will automatically stop in pos. 1 or 2. This operation must be repeated each time the pump is started and also when reversing the rotational direction. Pumps with this starting position should not be used for automatic working (for example with level sensors).

With CE Compliant control panels there is a start button which needs to be pressed before each pump start up and every time the panel is connected to a power source in case of a voltage drop.

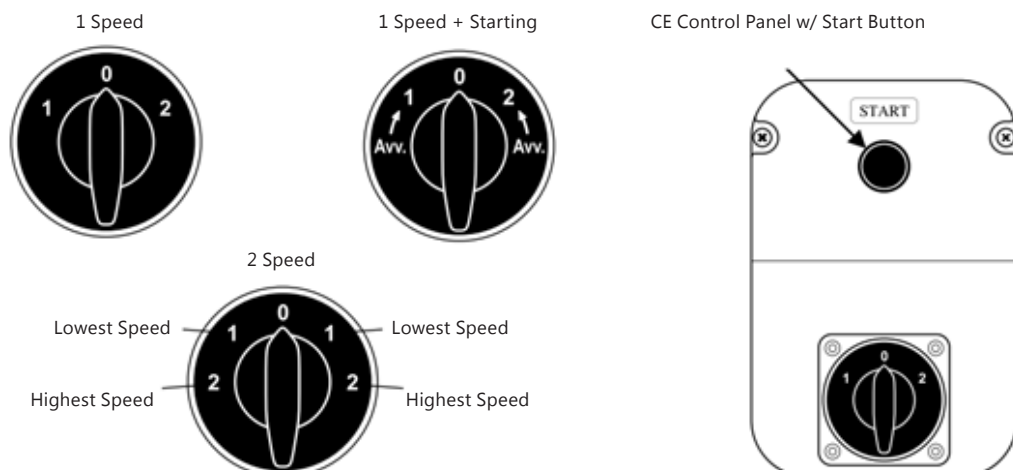



2. Dry run protection - The dry run protection device is connected directly to the pump body in the form of a temperature sensor (1), which stops the pump when the internal temperature is higher than 50 °C, in order to avoid burning or deformation of the impeller.

The standard temperature sensor is not suitable for the transfer of liquids at a temperature higher than 45 °C. Higher temperature rated sensors are available on request (70°C & 90°C Rated) when the pump is required for transferring fluids above 45°C.

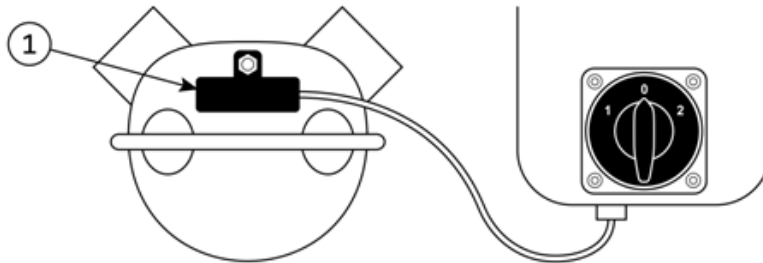

Please note that the dry run protection device does not interrupt the passage of electric current. Therefore, once the temperature inside the pump body drops below 50°C the pump will automatically start up again.

3. Frequency converter operation with remote control - The pump is directly operated through a remote control wired to the control panel via a 10 or 15 metre long cable. The remote features an On / Off / Reversing Switch (B) and a Speed Controller (A). The pump speed can be adjusted at will, even whilst the pump is running, according to the required capacity.

Before using the remote control the main control panel must be switched on by turning the mains switch (C) from the position 0 to the position 1. The panel also has an additional, optional, dry run protection feature and 24V shunt (normally closed contact) which allows the connection of other devices such as pressure switches, level sensors, flow meters, remote controls, etc...

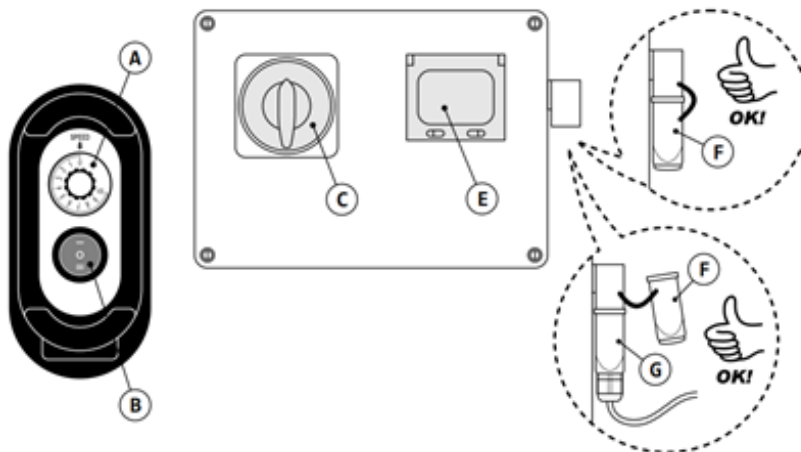

The Frequency Converter operating parameters are pre-programmed before supply and no other modifications are required. It is not recommended to use the small viewing panel (E) on the panel unit and any modifications to the parameters of Frequency Converter can result in improper operation of the pump and may invalidate the warranty. Please note that the pump will only work if the 24V Shunt is connected to the plug (F) or connected via an external device which closes the electrical circuit through the supplied connector (G).

4. Frequency converter with radio control - The pump is directly operated through a radio controller. After the pump has been switched on through the main switch, it is possible to control the pump directly from the main control panel or through the radio remote control (except the minimum speed restart function). The functions of the remote control are mirrored on the main control panel by the lighting of the corresponding buttons; for example, pushing the red stop button on the radio control, will turn on the red light button on the panel. The controller can be used effectively in a 100m radius of the apparatus.



Command descriptions and optical signals:

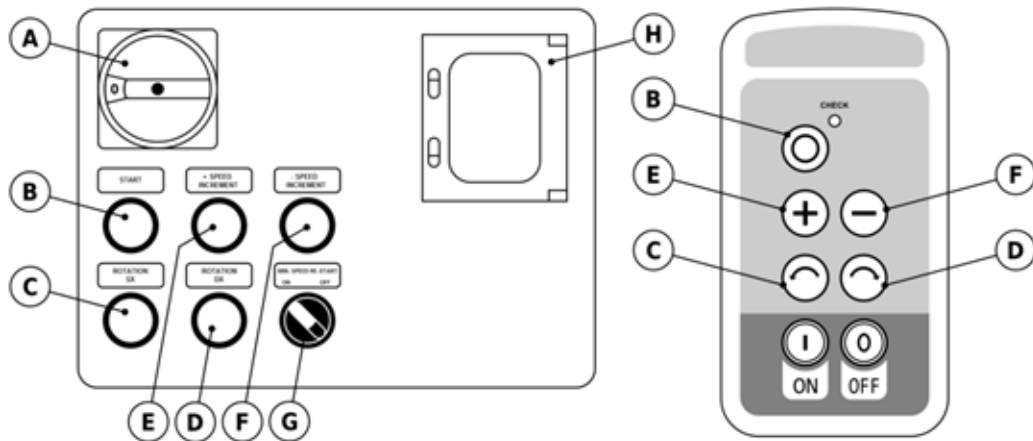

MAINS SWITCH [A] – The mains switch turns the control panel On / Off and acts as an isolating switch. When the control panel is turned on, the frequency converter display [H] turns on as well and the pump is in the STOP position, indicated by the red button illuminating [B].

STOP BUTTON (RED) [B] – By pressing the STOP button the pump is stopped. On the control panel, the illumination of the STOP signal has 2 different functions:

Constant light if the stop command was given by the operator (stop until other command)

Flashing if the stop signal was given by an external signal, i.e. the radio controller (temporary stop related to the external signal).

LEFT ROTATION BUTTON [C] OR RIGHT ROTATION BUTTON [D] – These buttons control the left and right rotation of the pump (on the control panel the corresponding button will light). On the control panel the illumination of the right and left buttons has different meanings:

Constant light shows the pump is running in the set direction

Flashing light shows the pump has been stopped by the operator, this illumination is intended to indicate the rotation before the STOP of the pump.

It is possible to reverse the direction of rotation of the pump even whilst the motor is running. The changeover will be made according to the acceleration / deceleration set in the frequency converter (these values vary depending on the model of the pump).

INCREASE [E] OR DECREASE [F] BUTTONS – These buttons increase or decrease the rotational speed whilst the pump is running (on the control panel the corresponding button will light up). The speed will vary proportionally; with a short press you will have little variation, with a long press will have a linear variation up to the minimum / maximum value set (the minimum / maximum values vary in relationship to the model of pump).

MINIMUM SPEED RE-START SELECTOR [G] – Set to ON: the Minimum restart function is activated, after the pump has been STOPPED by the user, it restarts at the minimum speed.

Set to OFF: the Minimum restart function is disabled, after the pump has been STOPPED by the user, it restarts at the speed achieved before the STOP.

Attention: This setting only works when the user stops the pump. If an external source stops the pump (ex. thermal sensor or other) it will restart at the speed set before the stop.



Accessories:

Stainless Steel Covers, Baseplate or Trolley Mounted:

- Sanitary Enclosures for use in food environments & Wash Down Areas
- White Food Grade Wheels
- CE Compliant Control Panel w/ Reversing Switch
- Sanitary Inlet / Outlets (DIN, SMS, Tri-Clamp, RJT Etc...)



Automatic Barrel Filling Kit:

Stainless Steel Automatic Gun with regulation trimmer (wine-alcohol) ,12V rechargeable battery, non-return valve, pressure switch & ø30 mm nozzle

Built entirely in stainless steel with IP55 control box.

Easy to use, allows a quick setting of the desired level. Sensitivity adjustment for filling liquids with high alcohol content and response delay setting in case of foaming liquids.

It can be used on stacked barrels, thanks to small footprint

Works without cables, with 12V rechargeable battery and signal LED.

Available with all standard fittings

Maximum capacity: 120 l/min at 0.7 bar, 210 l/min at 1.9 bar

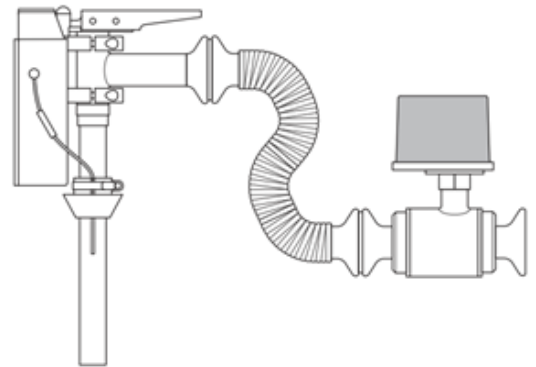

IRR Sprinkler::

Centrifugal Sprinkler which, thanks to its special design, rotates using the pressure of the feed pump. Provides uniform drizzling of the cap that grants an excellent colour leaching. Standard fastening system for 400 mm manways, on request fastenings can be supplied for larger manways.

Standard Models:

IRR 50: Suitable for pumps with capacity from 100 to 225 hl/hour

IRR 65: Suitable for pumps with capacity from 225 to 500 hl/hour

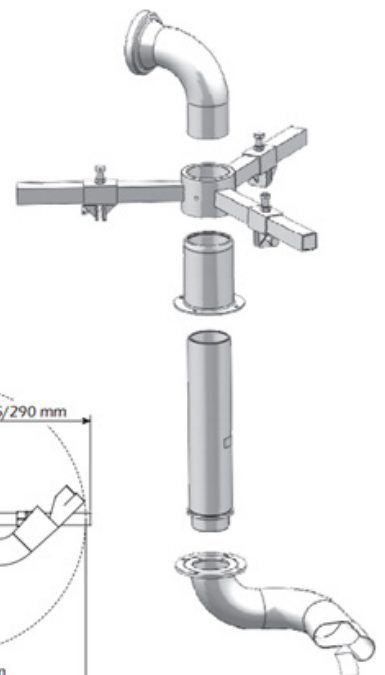
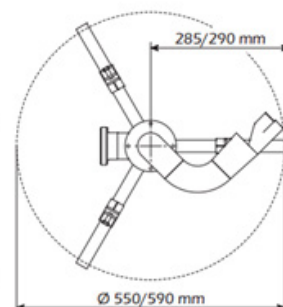
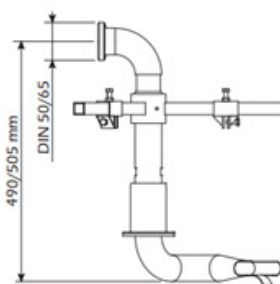



Spare Parts:

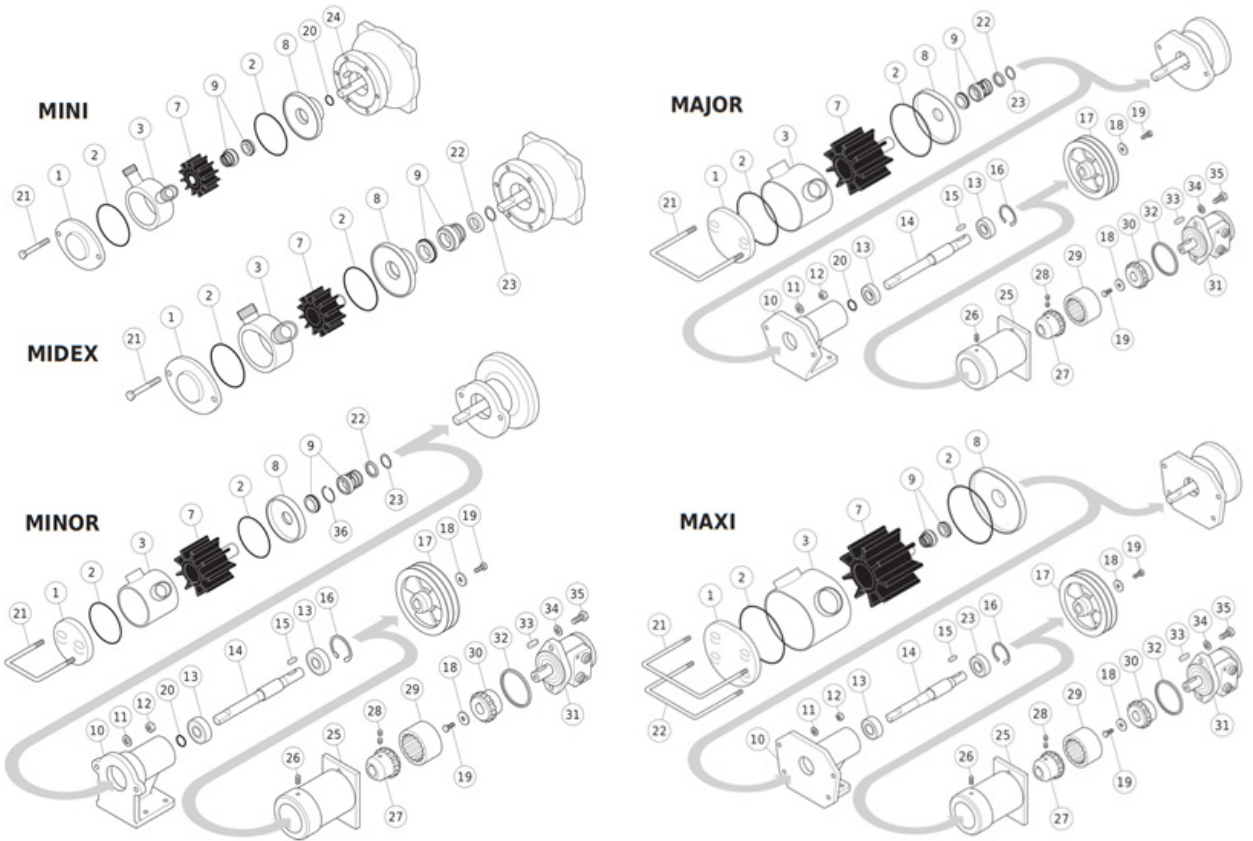



POS.	DESCRIPTION	MATERIAL	MINI	MIDEX	MINOR	MAJOR	MAXI
1	Front Cover	SS 304			X	X	X
		SS 316	X	X			
2	Casing O-Ring	NBR	X	X	X	X	X
3	Casing	SS 304			X	X	X
		SS 316	X	X			
7	Impeller	Natural Rubber, NR	X	X	X	X	X
		Neoprene, CR	X	X	X	X	X
		NBR	X	X	X	X	X
		EPDM	X	X	X	X	X
		Silicon, VQM			X	X	X
8	Rear Cover	SS 304			X	X	X
		SS 316	X	X			
9	Mech. Seal	SS / Graph / NBR	X	X	X	X	X
		Tungsten Carbide / NBR	X	X	X	X	X
		Tungsten Carbide / Viton	X	X	X	X	X
10	Support (S/P)	Aluminium			X	X	X
	Support (MID)	Aluminium			X	X	X
11	Washer	SS 304			X	X	X
12	Nut	Chromate Brass			X	X	X
13	Ball Bearing	Commercial			X	X	X
14	Shaft	SS 420			X	X	X
15	Flat Key	SS 304			X	X	X
16	Seeger Ring	Steel			X	X	X
17	Pulley	Aluminium			X	X	X
18	Washer	SS 304			X	X	X
19	Bolt	SS 304			X	X	X
20	Guard Ring	NBR	X		X	X	
21	U-Bolt	SS 304			X	X	X
	Bolt	SS 304	X	X			
22	U-Bolt	SS 304					X
	Spacing Ring	SS 304					
23	Seeger Ring	SS 304		X	X	X	
	Ball Bearing	Commercial		X	X	X	
24	Flat Key	SS 304					X
25	MID Flange	Aluminium	X				
26	Bolt	Steel			X	X	X
27	Pump Coupling	Steel			X	X	X
28	Bolt	Steel			X	X	X
29	Box Coupling	Nylon			X	X	X
30	Motor Coupling	Steel			X	X	X
31	Orbital Motor	Commercial			X	X	X
32	Center Ring	SS 304			X	X	X
33	Flat Key	Steel			X	X	X
34	Washer	SS 304			X	X	X
35	Bolt	SS 304			X	X	X
36	Seeger Ring SB 50 Int.	Steel			X		