



# Air-operated INDUSTRIAL PUMPS

oil and similar products



Ratio **5:1**  
Flow rate **45 l/min**

## Double action series 900 air-operated industrial pumps for distribution.

Suitable for transferring oils, lubricants and similar products, also high viscosity. The double action guarantees the delivery of a continuous and constant flow. Ideal for every needs. Particularly effective in systems equipped with several dispensing points.

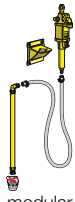

series **900**

Article with seals in	PU	integral <b>90C/51</b>	flanged <b>90F/51</b>
Compatible fluids		Oils, lubricants and similar	
Suction tube upper body		Aluminium	
Suction tube		Carbon steel	
Air inlet connection	bsp	F 1/2"	F 1/2"
Fluid outlet connection	bsp	F 3/4"	F 3/4"
Max. air consumption 8 bar	m <sup>3</sup> /min	1,6	1,6
Noise level	dB	80	80
Air max. feed pressure	bar	8	8
			
		modular	modular
Packing	N° - m <sup>3</sup>	1 - 0,040	1 - 0,040
Weight	Kg	12	13
Dimensions (A - B - C)	cm	43 - 27 - 6,2	44,5 - 27 - 6,2



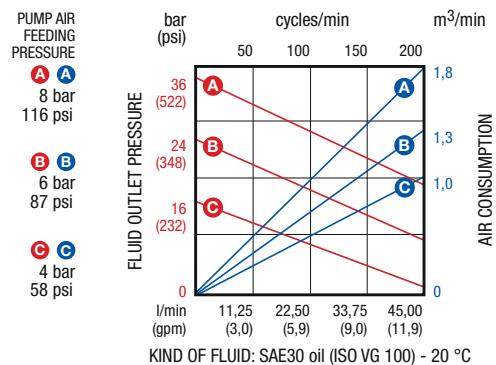

Suitable for drums or tanks

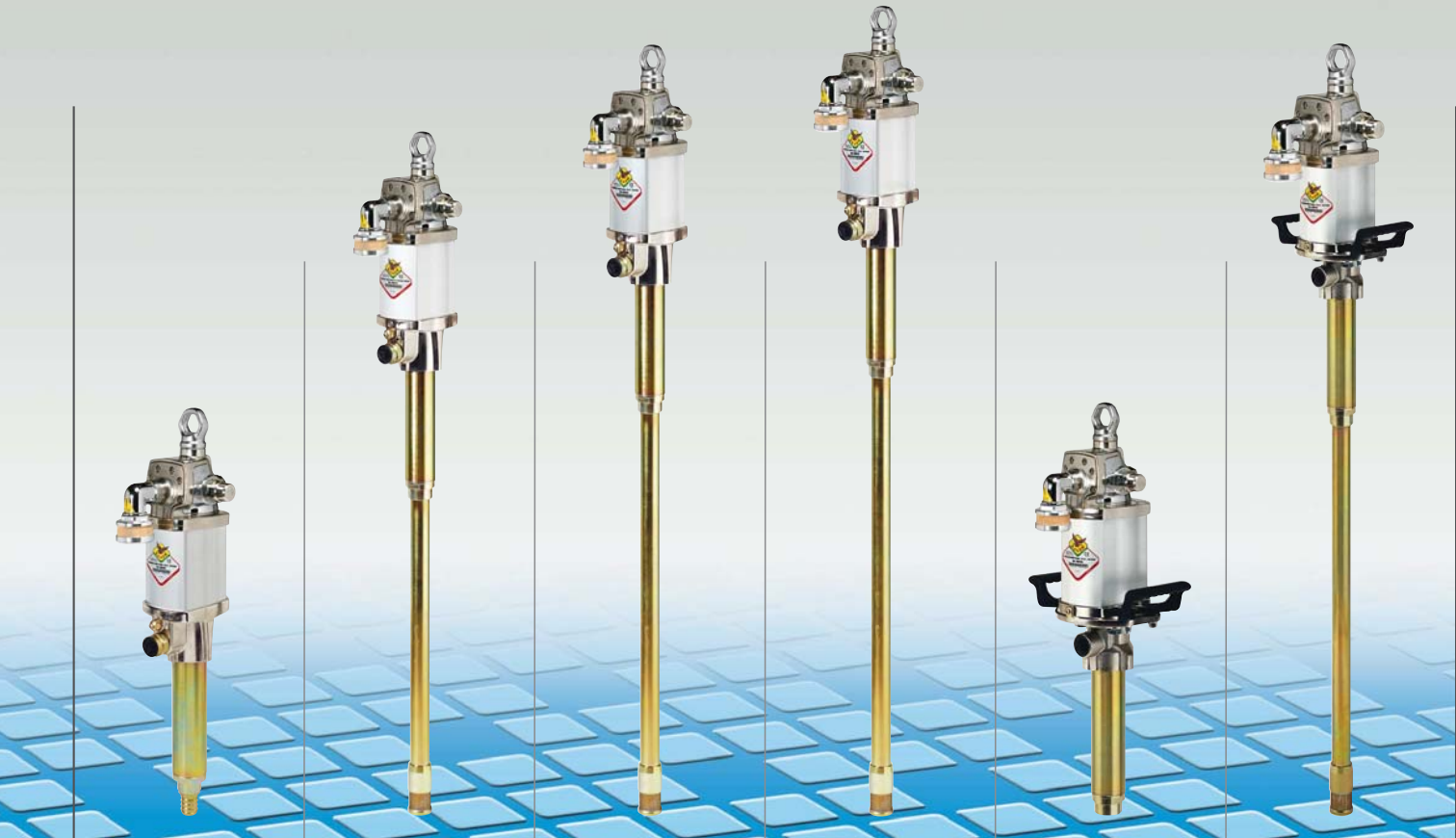

**Ratio 7:1**  
**Flow rate 30 l/min**

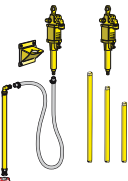
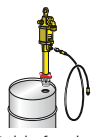

**series 900**

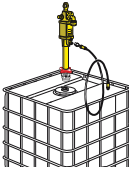
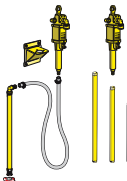
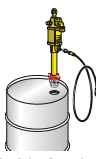
integral	integral	integral	integral	flanged	flanged
90C/71	93C/71	91C/71	92C/71	90F/71	91F/71
Oils, lubricants and similar				Oils, lubricants and grease	
Aluminium				Carbon steel	
Carbon steel				Carbon steel	
F 1/2"	F 1/2"	F 1/2"	F 1/2"	F 1/2"	F 1/2"
F 3/4"	F 3/4"	F 3/4"	F 3/4"	F 3/4"	F 3/4"
1,6	1,6	1,6	1,6	1,6	1,6
80	80	80	80	80	80
8	8	8	8	8	8
					
modular	suitable for drums 50-60 Kg	suitable for drums 180-220 Kg	tank	modular	suitable for drums 180-220 Kg
1 - 0,040	1 - 0,080	1 - 0,080	1 - 0,080	1 - 0,040	1 - 0,070
11	13,5	14,5	15	12	14
43 - 27 - 5,3	43 - 74 - 5,3	43 - 94 - 5,3	43 - 126 - 5,3	44,5 - 27 - 5,3	44,5 - 94 - 5,3

PUMP AIR FEEDING PRESSURE

- A** 8 bar 116 psi
- B** 6 bar 87 psi
- C** 4 bar 58 psi

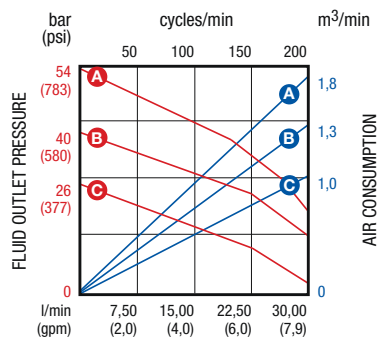

KIND OF FLUID: SAE30 oil (ISO VG 100) - 20 °C



# Air-operated INDUSTRIAL PUMPS



oil and similar products

Ratio **11:1**  
Flow rate **30 l/min**

## Double action series 900 and 1200 air-operated industrial pumps for distribution.

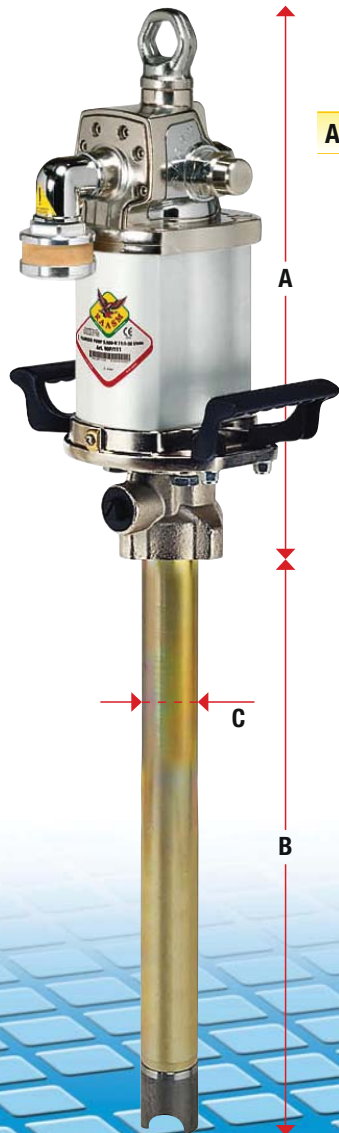
Suitable for transferring oils, lubricants and similar products, also high viscosity. The double action guarantees the delivery of a continuous and constant flow. Ideal for every needs. Particularly effective in systems equipped with several dispensing points.

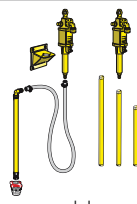

Article with seals in		PU	90C/111	92C/111	91C/111
Compatible fluids			Oils, lubricants and grease		
Suction tube upper body			Aluminium		
Suction tube			Carbon steel		
Air inlet connection	bsp		F 1/2"	F 1/2"	F 1/2"
Fluid outlet connection	bsp		F 3/4"	F 3/4"	F 3/4"
Max. air consumption 8 bar	m <sup>3</sup> /min		1,7	1,7	1,7
Noise level	dB		80	80	80
Air max. feed pressure	bar		8	8	8
Suitable for drums or tanks			 modular	 suitable for drums 50-60 Kg	 suitable for drums 180-220 Kg
Packing	N° - m <sup>3</sup>		1 - 0,040	1 - 0,070	1 - 0,070
Weight	Kg		11	15	16
Dimensions (A - B - C)		cm	43 - 27 - 4,5	43 - 74 - 4,5	43 - 94 - 4,5

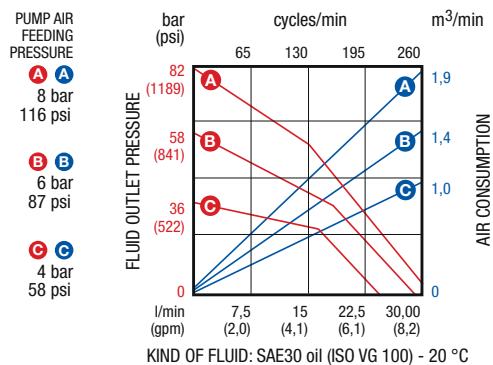







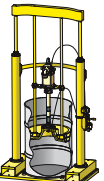

Ratio **9:1**  
Flow rate **45 l/min**

Ratio **12:1**  
Flow rate **30 l/min**

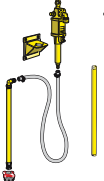
Ratio **18:1**  
Flow rate **23 l/min**

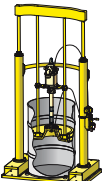

series 900		series 1200		series 1200		series 1200	
flanged		flanged		flanged		flanged	
90F/111	91F/111	115F/91	115F/121	116F/121	115F/181	116F/181	116F/181
Oils, lubricants and grease		Oils, lubricants and similar		Oils, lubricants and similar		Oils, lubricants and grease	
Carbon steel Carbon steel		Carbon steel Carbon steel		Carbon steel Carbon steel		Carbon steel Carbon steel	
F 1/2"	F 1/2"	F 1/2"	F 1/2"	F 1/2"	F 1/2"	F 1/2"	F 1/2"
F 3/4"	F 3/4"	F 3/4"	F 3/4"	F 3/4"	F 3/4"	F 3/4"	F 3/4"
1,7	1,7	2,8	2,8	2,8	2,8	2,8	2,8
80	80	80	80	80	80	80	80
8	8	8	8	8	8	8	8
							
1 - 0,045	1 - 0,070	1 - 0,40	1 - 0,040	1 - 0,070	1 - 0,045	1 - 0,070	1 - 0,070
13	17	14	13	15	15,5	18	18
44,5 - 48 - 4,5	44,5 - 94 - 4,5	44,5 - 23 - 6,2	44,5 - 23 - 5,3	44,5 - 94 - 5,3	44,5 - 48 - 4,5	44,5 - 94 - 4,5	44,5 - 94 - 4,5

