

### 1. Suction Conditions -

Mark box with an **X** to indicate type of application, and please specify **dimension H** & **tank pressure** (where applicable) on the lines provided.

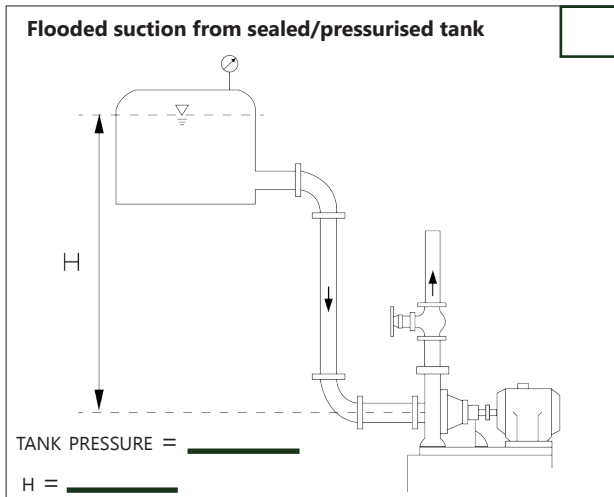
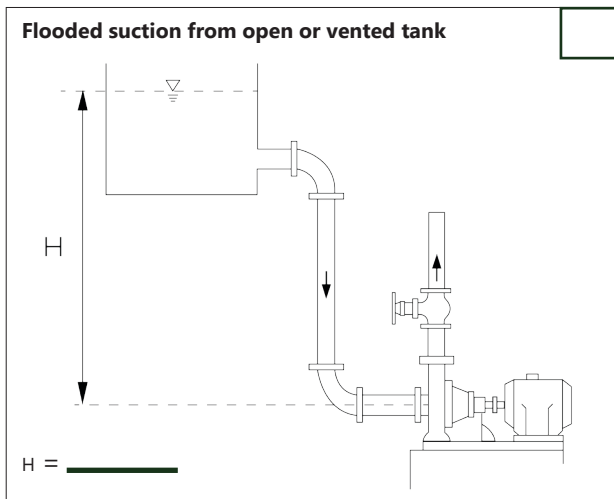
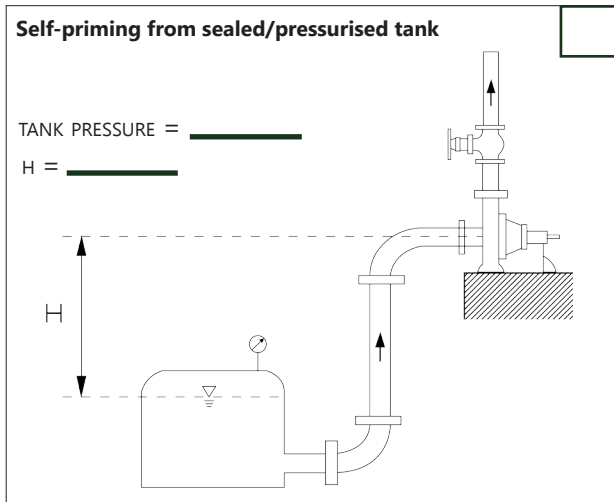
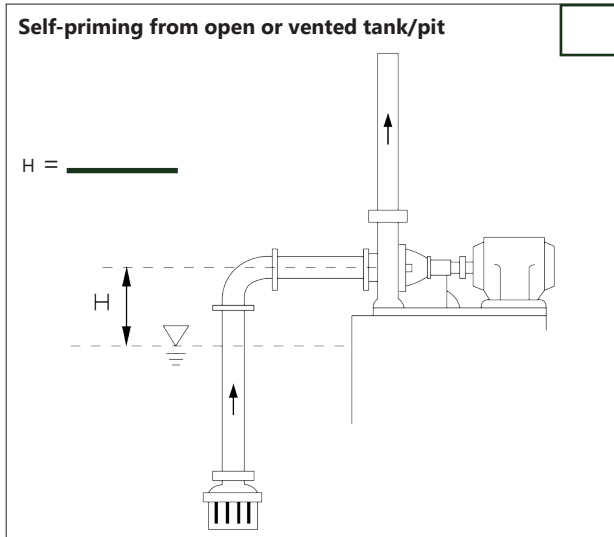

# PUMP SPECIFICATION FORM

return to: sales@castlepumps.com

### 2. Please fill in the table to the best of your knowledge.

Application:			
Liquid:			
Pump Orientation:	Horizontal <input type="checkbox"/>	Vertical <input type="checkbox"/>	Immersed <input type="checkbox"/>
Flow Rate:		Viscosity:	
Inlet Pressure:		Temperature:	
Outlet Pressure:		Voltage:	
Head/Pressure:		Frequency:	
Specific Gravity:		IP Protection:	

### 3. Installation Type -

Mark box with an **X** to indicate installation type, and please fill in the table referring to the diagrams where necessary.

Dimension A:	
Dimension B:	
Dimension C:	
DNa Suction Diameter:	
DNd Discharge Diameter:	
Flange Type:	
Flange Rating:	

