

eOne MA



www.etatrons.com

 **ETATRON D.S.**

- IT** NORME DI INSTALLAZIONE, USO E MANUTENZIONE
- UK** OPERATING INSTRUCTIONS AND MAINTENANCE
- FR** NOTICE D'INSTALLATION, EMPLOI ET ENTRETIEN
- ES** NORMAS DE INSTALACIÓN, USO Y MANUTENCIÓN

www.castlepumps.com



UNI EN ISO 9001-2008

SAFETY	21
Warnings	22
Symbols used in this manual	22
Dangerous and/or toxic liquid dosage	22
GENERAL REGULATION	22
Proper use of the pump	22
Shipping and handling.....	22
Risks	23
Assembly	23
Dismantlement	23
Warranty	23
ANALOGIC DOSING PUMPS EONE MA SERIES	24
Operating principles.....	24
Technical Characteristics	24
Overall dimensions	25
Material in contact with the additive	25
INSTALLATION	26
Introduction	26
Pump installation	26
Tubes connection	26
Electrical scheme.....	27
Typical installation	28
Accessories	29
REGULATIONS FOR SULPHURIC ACID ADDITIVE (MAX. 50%)	29
OPERATING INSTRUCTIONS	30
Manual Pump.....	30
Commands	30
Commands description	30
UNDER-LOAD and OVER-LOAD functions.....	31
Level alarm	31
ORDINARY MAINTENANCE	31
EXTRAORDINARY MAINTENANCE	32
MECHANICAL FAULTS	32
ELECTRICAL FAULTS	32
APPENDIX 1 – PUMP DRAWINGS	33
APPENDIX 2 – EXPLODED VIEWS	34
APPENDIX 2 – EXPLODED VIEWS	35

SAFETY

Warnings

Carefully read the warnings listed below as they contain important information regarding safety during installation, use and maintenance.



Keep this manual in a safe place for further consultation.

This equipment complies with the 2004/108/EEC directive regarding "electromagnetic compatibility" with the 2006/95/CEE "low voltage directive".

NB: The pump is manufactured to high working standards. Its working life will be longer and its mechanical/electrical reliability will be more efficient if used correctly and if subject to regular maintenance.

WARNING: Any internal repairs or operations to the equipment must be carried out by qualified and authorized personnel. The manufacturer declines all responsibility whatsoever due to non observance of these regulations

Symbols used in this manual

		
FORBIDDEN Before safety information, it highlights an operation not to be performed.	ATTENTION Before a very important notes regarding health protection for the exposed personnel or regarding the machine itself.	INFORMATION Before information regarding equipment use.

Dangerous and/or toxic liquid dosage



To avoid damage to persons and property due to contact with dangerous liquids or by the inhalation of toxic vapours, always adhere to the instructions container in this booklet and keep in mind the following regulations:

- Perform operations according to the instructions of the liquid manufacturer.
- Check the hydraulic parts of the pump for damage and breakages and only use the pump if it is in perfect working order.
- Use small piping fit for the liquid being used and for the plant operating conditions, if necessary, insert the tube inside PVC protection conduit.
- Before deactivating the dosing pump, neutralize the hydraulic part using an appropriate reagent.

GENERAL REGULATION

Proper use of the pump



The pump must only be used for the purpose which it was expressly manufactured, i.e to dose liquids. Any other use is considered improper and therefore dangerous. The pump is not foreseen for use in any applications not taken into consideration during the design stage. For further clarifications the customer must contact our offices where the user will receive information about the type of the pump in his possession and its correct use. The manufacturer cannot be considered responsible for any damage derived from improper, erroneous and unreasonable use.

Shipping and handling

Shipping must be performed in the same orientation as indicated on the packaging. Shipping using any means, even if delivered free to the customer, is considered at the purchaser's risk. Claims for missing material must be made within 10 days from goods receipt. Claims for defective material must be made within 30 days from goods receipt. Restitution of pumps must be agreed beforehand with authorized personnel or with the authorized distributor.



Risks

After removing the packaging, check the pump for any damage. If in doubt do not use the pump and contact qualified personnel. All packaging elements (such as plastic bags, polystyrene, etc.) must be kept out of the reach of children as the material is potentially dangerous.

Before connecting the pump, check that the data on the nameplate corresponds to the local voltage ratings. The data is available on the adhesive nameplate on the pump.

The electrical plant must be comply with any local regulations in the country where the pump is installed.

Observe some fundamental rules when using any type of electrical equipment, in particular:

- Do not touch the equipment with wet or damp hands or feet;
- Do not operate the pump without shoes (e.g. swimming pools);
- Do not leave the pump exposed to atmospheric agents (rain, sun, etc.)
- Do not allow the pump to be used by children or unskilled individuals without supervision.

In case of faults and/or bad pump operation, turn off the pump and do not tamper. For any necessary repairs contact our specialized technical assistance centers and insist on the use of original spare parts. Any lack of respect to the above may compromise pump safety.

If the user decides to make no further use of an installed pump, it is recommended to render the pump in operative and disconnect it from the power supply.

If any liquid losses are present in the hydraulic system (due to O-ring seals, valves or piping breakages), stop the pump by releasing pressure in the discharge tube and then proceed with maintenance operations using adequate safety measures (gloves, goggles, overalls, etc.).

Assembly

All the pumps we produce are normally supplied fully assembled. For better clarification, consult the appendix at the end of this manual where exploded assembly drawings and views of the pumps are available together with all components and their nomenclature, for the user to have complete details of the pump components. These drawings are indispensable when searching for malfunctioning or defective parts. Other drawings refer to hydraulic parts (pump header and valves) and are shown for the same reasons in the appendix at the end of the booklet.

Dismantlement

To dismantle the pump or before performing pump maintenance, proceed as follows:

- Make sure the pump is electrically deactivated (both poles) by disconnecting the conductors from the power supply using the omnipolar switch which must have a minimum distance of 3mm between its contacts (Fig.6).
- Relieve the pressure in the pump head and the discharge tube in the most adequate way possible (be very careful during this operation).
- Drain the liquid present in the pump head by disassembling and reassembling the pump head using the four fixing screws, tightening torque 180÷200 N*cm (Appendix 1).

Please pay particular attention to this last point and we recommend the user to consult the enclosed drawings and chapter "**RISKS**" before starting any operations.

Warranty

2 years (normal wear on parts is excluded, i.e.: valves, fittings, piping ring nuts, piping, filter and injection valve). Improper equipment use invalidates the warranty. The warranty is intended ex works or at an authorized distributor.



ANALOGIC DOSING PUMPS EONE MA SERIES

Operating principles

Dosing pump operation is ensured by a PTFE (teflon®) membrane mounted on the piston of an electromagnet. When the piston of the electromagnet is attracted, pressure is produced in the pump head and liquid is ejected from the discharge valve. Once the electrical impulse has terminated a spring brings the piston back to its original position and liquid is called in through the suction valve. Due to this simple operation of the pump, no lubrication is needed and maintenance is reduced to nearly zero. The materials used to manufacture the pump make it fit for use even with particularly aggressive liquids. The dosing pump has been designed for flow rates starting from 1 to 30 l/h and pressures from 4 to 20 bar (depending on pump type).

Technical Characteristics



- Equipment manufactured according to CE regulation
- Anti acid plastic casing
- Control panel protected by adhesive film resistant to atmospheric agents and UV rays
- Power supply: extended range 90 – 260 Volt 50-60 Hz
- IP65 protection level
- Environmental conditions: closed environment, altitude up to 2000 m, ambient temperature from 5°C to 40°C, maximum relative humidity 80% up to a maximum of 31°C (linear decrease down to 50% at 40°C).
- Classification with respect to protection against indirect contacts: CLASS I (the equipment is supplied with an electrical protection conductor).

The pump is equipped with a power board that adjust the absorbed power against the back pressure. The absorbed power has to be considered at the maximum working pressure

The following table shows the values of power consumption depending on the back pressure.

Reference Standards

The dosing pump is in accordance with the following directives:

- 2006/95/CE: " low tension"
- 2004/108/CE: " electromagnetic compatibility"

Type	Max Flow rate			Max Pressure [bar]	Stroke [imp/1']	Standard power supply	Power adsorbed [W]	Current MAX [A]	Net weight [kg]
	L/h	mL/min	mL/colpo						
0101	1	16,66	0,09	8	0 – 180	100 -250 V / 50-60 Hz	19	1,4	3,0
0310	3	50,00	0,21	10	0 – 240		21	1,4	3,0
0507	5	83,33	0,27	7	0 – 300		21	1,4	3,5
0520	5	83,33	0,46	20	0 – 180		28	2,0	4,5
0810	8	133,33	0,45	10	0 – 300		26	1,8	3,5
1010	10	166,66	0,55	10	0 – 300		36	1,8	4,5
1504	15	250,00	0,83	4	0 – 300		26	1,8	3,5
2005	20	333,33	1,38	5	0 – 240		32	1,9	4,5
3005	30	500,00	2,08	5	0 – 240		32	1,9	4,5
0210(*)	2	33,33	0,18	10	0 – 180		36	1,6	3,0
0507(*)	5	83,33	0,46	7	0 - 180		36	1,6	3,0

(*) only model BASIC

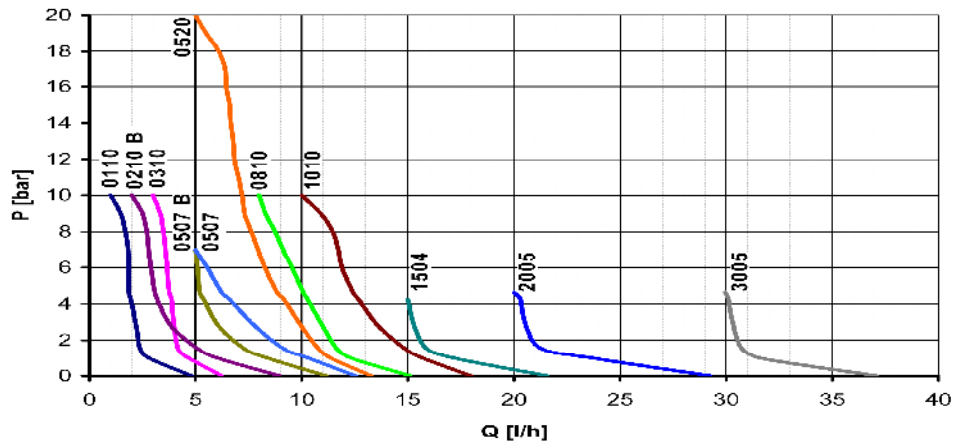

The values listed above are intended to be within a tolerance of +/- 5%. They were obtained by a series of test performed on similar equipments with water at temperature of 20°C.

Overall dimensions

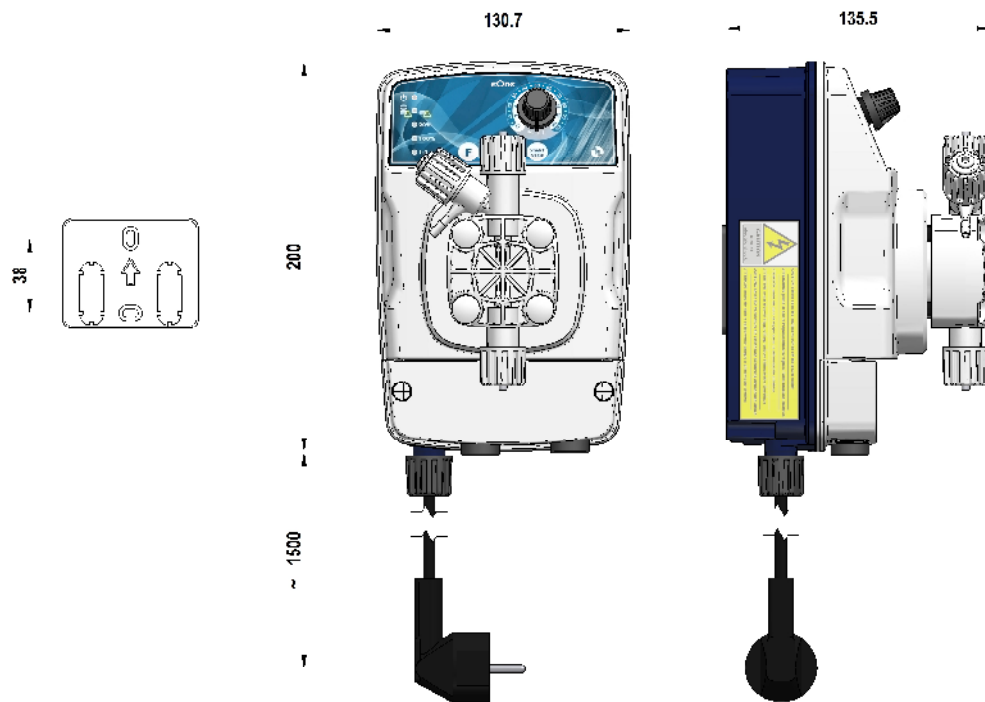

Fig. 1 - Dimensions in mm

Material in contact with the additive



Pump Head	Diaphragm	Seals	Valves	Nipples	Hosing
PVC	PTFE	TFE	CERAMIC TFE/P	PVDF	PE / PVC

INSTALLATION



Introduction

This section describes steps for installing the pump, hoses and wiring. Please read this instruction before starting any activity.

Follow these guidelines when installing the pump:

- Make sure the pump is powered off and any other related equipment before starting any activity.
- In case of any unusual events or warning signs, stop immediately. Start again only when you are absolutely sure that any possible problem has been solved.
- Do not install the pump in hazardous environments such as at risk of fire or explosion.
- Avoid risk of electrical type and or fluid leakage. Never use a damaged or defective pump.

Pump installation

Install the pump away from heat sources, in a dry place and at a maximum ambient temperature of 40°C. The minimum operating temperature of the pump depends on the liquid to be dosed, as the liquid must remain a fluid state. If the pump has been stored at an ambient temperature of less than 0°C, make sure that any water present in the pump head is in a liquid state before starting up the pump.

Locate the pump as shown in fig. 2 taking into account that it can be located over or under the liquid level within a maximum difference of 2 meters. The injection point must always be located higher than the liquid to be dosed.

If the plant being treated operates at atmospheric pressure (free discharge additive) and the additive tank must be placed higher than the injection point (Fig. 2), check periodically that the injection valve is operating correctly, as excessive wear could cause additive injection by liquid loss (even when the plant is not operating). If the problem persists, insert a correctly calibrated **counter pressure valve C** between the dosing pump and the injection point (Fig. 6).

For liquids that give off aggressive exhalations, do not install the pump over the tank unless the tank is hermetically sealed.

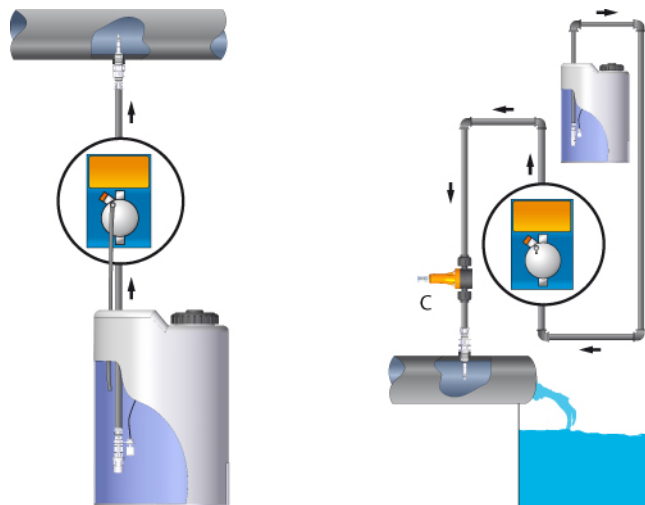

Fig.2

Tubes connection

The discharge nipple will always be at the top side of the pump from where the tube goes to the plant to be treated. The suction nipple will always be at the bottom side of the pump, where the tube will be mounted with the filter that goes to the tank of the liquid to be dosed.

1. Remove the seal from ring nut (2)
2. Insert tube through ring nut (2) and bush (3)
3. Press the hose end (1) onto the conic adapter of the nozzle (4)
4. Place the nozzle (4) onto the nipple (5)
5. Tighten the ring nut (2) onto the nipple (5)

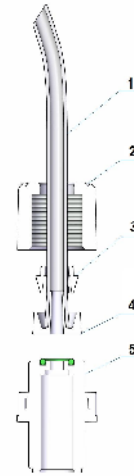

Fig.3

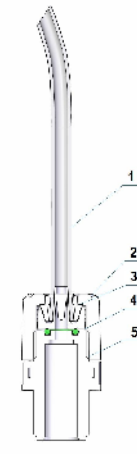

Fig.4

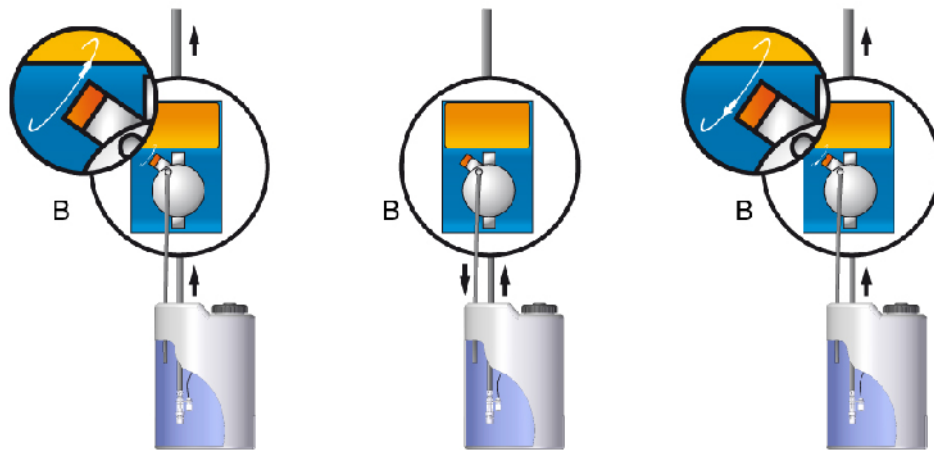

Fig.5

To prime the pump: Connect the discharge tube and follow the sequence shown in Figure 5. Unscrew the drain knob, the pump has to be turned on, keep open the bleed valve B until all the air, inside the tube and inside the pump head, is out, close the drain knob. In case of difficulty, use a syringe connect to the bleed nipple and extract the air, decreasing the number of pulses.

Electrical scheme

Respect the regulations in force in different countries concerning the electrical installation. If the power cable has no plug, the equipment must be connected to the power supply using an omnipolar switch with a minimum distance of 3 mm. Before accessing the power connection devices, **all power circuits must be interrupted (fig. 6).**

100 - 250 VAC 50/60 HZ

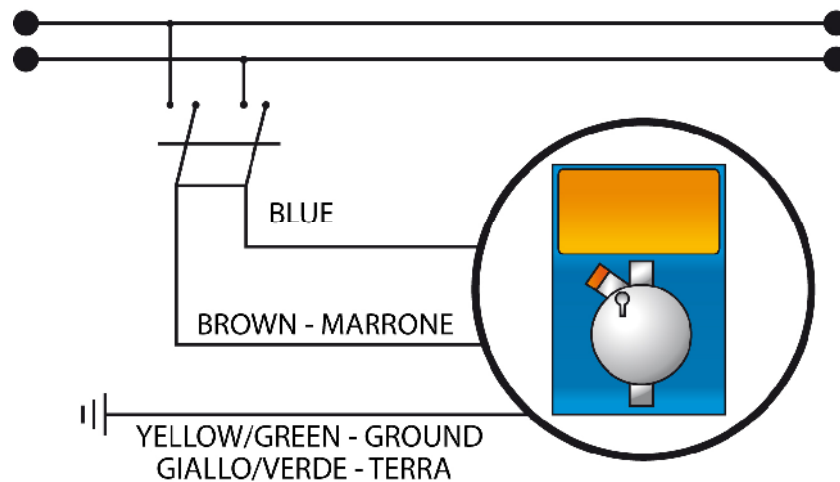

Fig.6

Typical installation

- A Main pipeline
- B Injection valve
- C Backpressure valve
- D Pressure gauge
- E Relief valve
- F Power supply plug
- G Chemical tank
- H Foot filter
- I Level probe

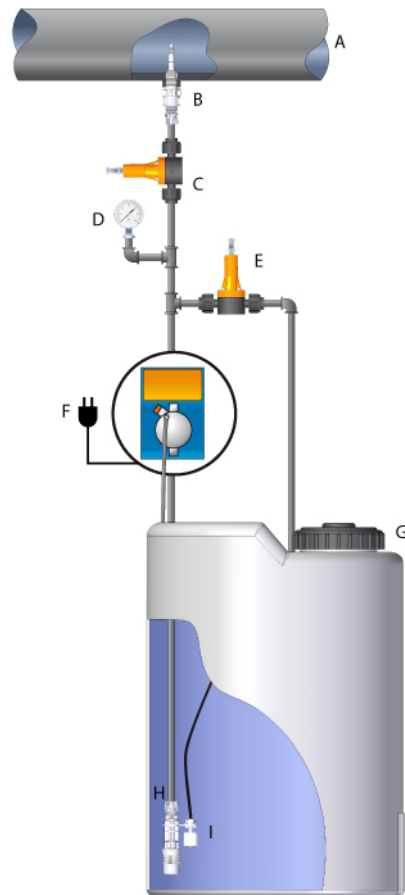

Fig.7



Avoid unnecessary curves and narrow on both the discharge and suction pipes. Apply a 3/8" or 1/2" BSP female nipple on the conduct of the plant to be treated, in the most suitable location for the injection of the product to be closed. This nipple is not supplied. Screw the injection valve on the nipple using PTFE tape as a seal (Figure 8). Connect the tube to the conical adapter of the injection valve and secure with the hose ring nut (4). The injection valve is also a no-return valve.

1. Plant being treated
2. conical connection 3/8" – 1/2" BSP
3. injection valve
4. hose ring nut
5. discharge pump hose
6. PTFE sealing type

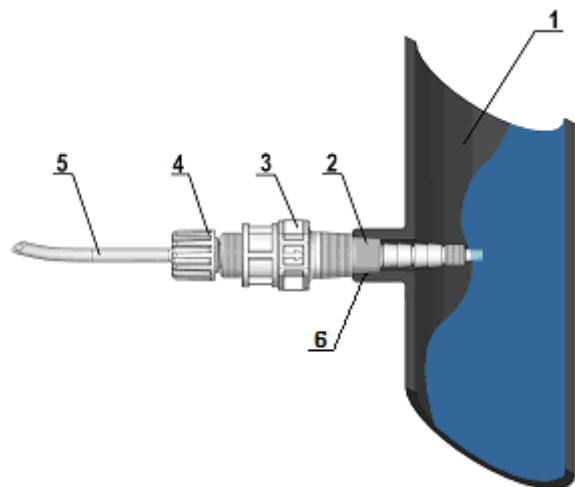

Fig.8

Accessories



Supplied with the pump are includes the following articles:

- n.1 flexible transparent PVC cristal suction hose, length 4m
- n.1 polyethylene semi-rigid white discharge hose, length 2m
- n. 1 3/8" BSP injection valve
- n.1 foot filter
- n.1 instruction manual

REGULATIONS FOR SULPHURIC ACID ADDITIVE (MAX. 50%)

In this case it is necessary to take into account the following:

- replace the flexible cristal PVC suction hose with semi-rigid polyethylene hose.
- Remove all water present in the pump head (if water mixes with sulphuric acid a great amount of gas is generated which will overheat the area and cause damage to the valves and pump head).



To perform this operation when the equipment is not fixed to the plant, the pump can be pulsed for seconds (15-30) keeping it overturned and without piping connected to the fittings. If this is not possible disassemble and reassemble the pump head (appendix 1) using the four fixing screws.

OPERATING INSTRUCTIONS

Manual Pump

Manual flow rate adjustment using a potentiometer to intervene on the injection frequency. Possibility of a more accurate flow control at low frequencies using the two buttons 20% and 100%.

Commands



Fig.9

1	Adjustment knob frequency (%) of the number of injections
2	START/STOP button
3	Button function selection: full scale 20/100% / entrance 1:1; activation and deactivation function UNDER-LOAD / OVER-LOAD held down for 5 sec.
4	1:1 function display external signal "green" LED
5	100% flow scale read out "green" LED
6	20% flow scale read out "green" LED
7	UNDERLOAD mode alarm (green LED), OVERLOAD mode alarm (red LED)
8	STAND BY mode (green LED flashing), operation mode (red LED flashing)

Commands description



- START/STOP button controls the activation and deactivation of the pump. Under stand-by mode (STOP) the green LED (8) flashing at long intervals;
- LED (8) signals the injections of the pump, "red" LED flashing, the pump operates;
- FLOW RATE ADJUSTMENT (knob 1) adjust the injection/minute of the pump until 100% of the maximum flow rate;
- FLOW RATE SCALE READ OUT;
- ALARM LEVEL: the pump is predisposed for level alarm (see section), the level alarm, the pump stop dosing and the LED (8) lights up red color;
- UNDER-LOAD (see section), the pump stop dosing and the red LED lights up;
- OVER-LOAD (see section), the pump stop dosing and the red LED lights up;

UNDER-LOAD and OVER-LOAD functions

The innovative HRS technology has allowed to create a range of metering pumps capable of detecting pressure changes within the plant or malfunctions associated with these changes. The pump is able to provide you with useful information about the status operation. This is possible through two types of signals.

a) **UNDER-LOAD:** where, in normal operation, the pump is missing the fluid, in addition to the normal lack of additive in the tank, could be caused by problems on the suction line: filter clogged or damaged valves, the pump is placed in a state of UNDER LOAD . This condition is indicated by the LED red lights up (7) and the pump stops after about 10 injections.

b) **OVER-LOAD:** The pump, during normal operation, performs a real-time control on the pressure conditions inside the plant to be treated. If this pressure exceeds the maximum allowed (factory default), the pc-board of the pump reacts lighting up the red LED (7) and stop the dosing after about 10 injections.

The OVER-LOAD and UNDER-LOAD functions can be enabled and disabled by pressing and holding (for about 5 seconds) the 20/100% button (3). A triple blink of the red LED (7) indicates that the function has been enable, while a triple blink of the same LED with green color (7) indicates that the function has been disabled. During this steps the pump stop dosing and start after the function has been enable/disable. **OVERLOAD and UNDERLOAD functions are disable by factory default.**

Level alarm

The pump is supplied with a connector for a level switch (supplied on request). When the height of the liquid in the product tank is lower than a predetermined minimum level, the level sensor alerts the user and stops the dosage after five seconds. The delay in stopping the metering pump is used to prevent any disturbance of the liquid level

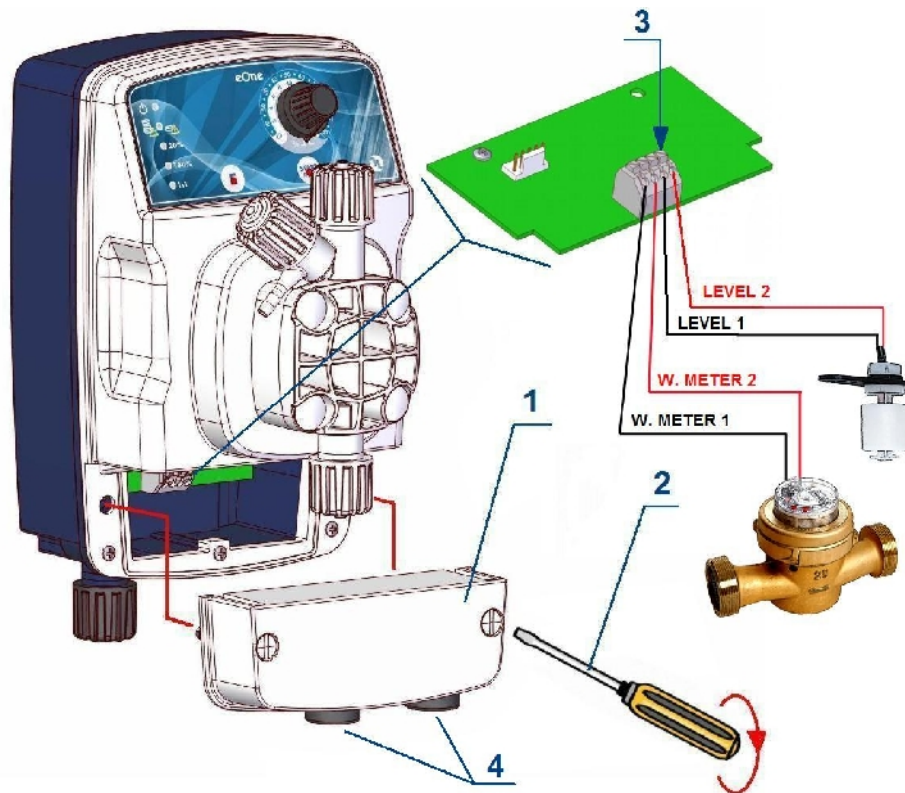

Fig. 10 – Level probe connection

ORDINARY MAINTENANCE



An Ordinary and accurate maintenance with a programmed check, guarantee the preservation over time and the proper functioning of the systems. Therefore we recommend that the user follow our advice and maintenance of a service contract and assistance programmed with one of our Technical Support Center.

Check at least every 6 months functioning of the pump. In case of intensive use of the metering pump, you should increase the frequency of these controls.

Check inside the pump head the presence of deposits, in this case they can be removed by disassembling the piece and washing it with water. If the deposits are difficult to remove, it is recommended to dip the part in an aqueous solution of hydrochloric acid, then rinse it with water.

Check regularly the seals of valves, diaphragm and any other seals, because as part of normal wear and tear may be subject to deterioration.

To replace the membrane remove the 4 screws, unscrew the membrane and replace the O-Ring, reassemble all pieces making sure to tighten the screws in a balanced way (screw alternately cross respecting the prescription of torque).

Check and replace the sealing of the injection valve as it may be subject to deterioration due to wear and serving as a check valve in the pump may cause a return of the product dosed.



Warning: When removing the pump from the plant act carefully removing the tube from the discharge nipple, as it could leak out the additive from the tube. Again, if the casing is in contact with the additive must be cleaned.

Warning: when the power supply is deactivated the pump may emit one or more pulses, so before you disconnect the tubes make sure that the pump is turned off completely.

EXTRAORDINARY MAINTENANCE



All components of our supplies are chosen and tested according to strict principles of selection, and then provide, for a long time, reliability and functionality in our devices.

MECHANICAL FAULTS

As the system is quite robust there are no apparent mechanical problems. Occasionally there might be a loss of liquid from the nipple because the tube nut has loosened, or more simply the discharge tubing has broken. Very rarely there may be losses caused by the breakage of the membrane, or by the membrane seals in which case they have to be replaced by disassembling the four screws of the pump head - appendix 1), when re-mounting the pump head ensure that the screws are replaced properly, along with "O" ring. After repair, the metering pump will need to be cleaned of additive residues which can damage the pump casing.

THE METERING PUMP GIVES PULSES BUT THE ADDITIVE IS NOT INJECTED

Dismount the suction and discharge valves, clean them and replace, see position (appendix 1). Should the valves be swollen, check valves material against our chemical resistance compatibility chart and fit correct valves..

- Check the dogging status of the foot filter;
- Check the injection valve.

ELECTRICAL FAULTS

ALL LEDS OFF, THE PUMP DOES NOT PULSE.

Check power supply (socket, plug, power switch ON), if the pump doesn't work contact manufacturer Customer Service, Dealer or Distributor.

APPENDIX 1 – PUMP DRAWINGS

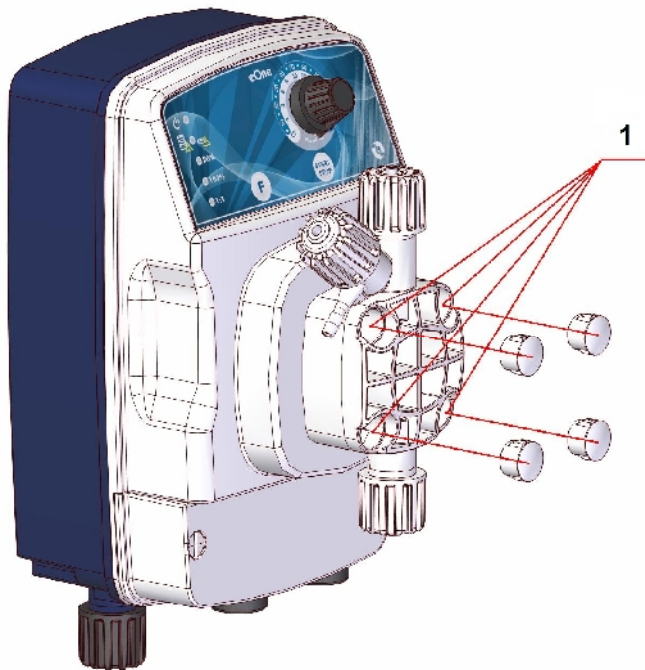

1. pump head screws

to tighten the four screws use a dynamometer screwdriver set to a tightening torque of 180-200 N \times cm using a hexagonal insert of 2,5 mm

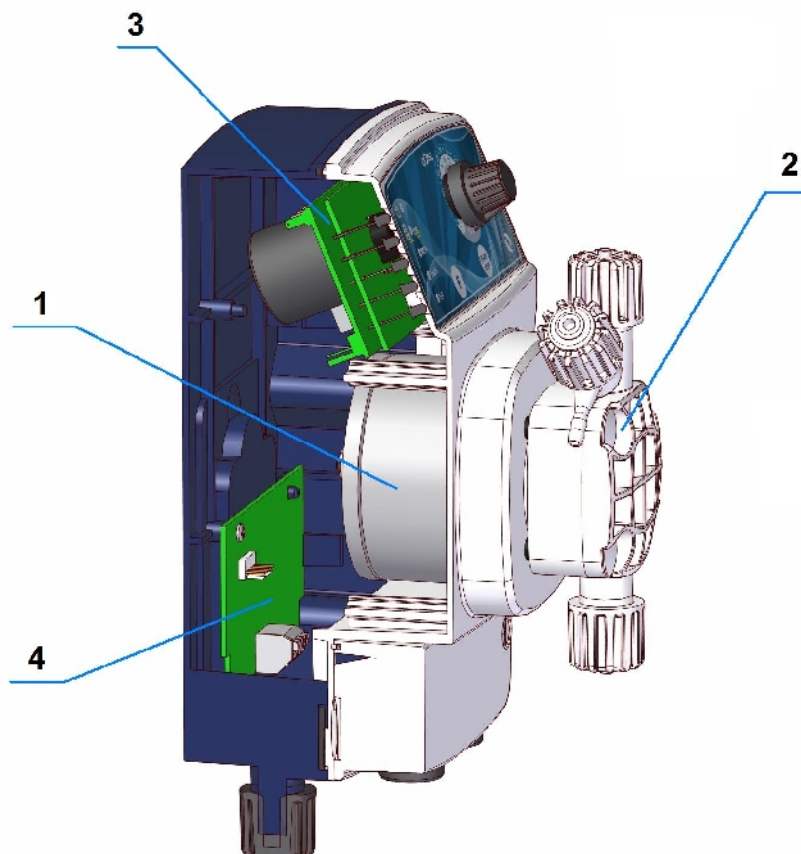

1 -ELECTROMAGNET

2 -PUMP HEAD

3-PC BOARD

APPENDIX 2 – EXPLODED VIEWS

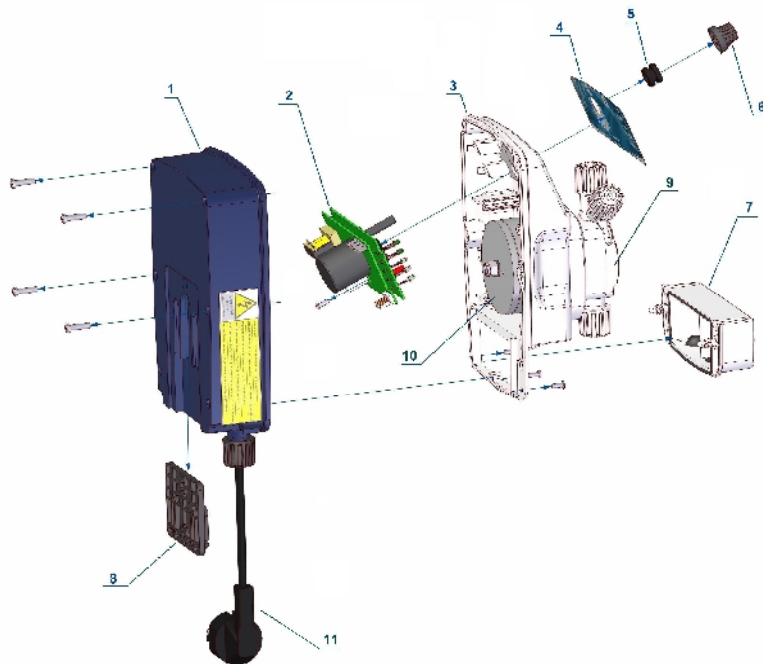

- 1. Plastic casing
- 2. Plastic cover
- 3. Pump head
- 4. Electromagnet
- 5. Pump gasket
- 6. PC-board
- 7. Knob basket
- 8. Adjustment knob
- 9. Flange
- 10. Diaphragm
- 11. Pump head basket

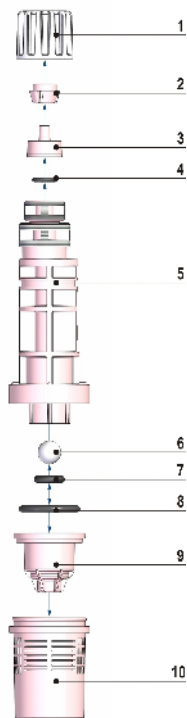

- 1. Ring nut
- 2. Bush
- 3. Nozzle
- 4. O-ring 106
- 5. Body filter
- 6. Ceramic ball
- 7. O-ring 3030
- 8. O-ring 3081
- 9. Valve seat
- 10. Filtering basket

APPENDIX 2 – EXPLODED VIEWS

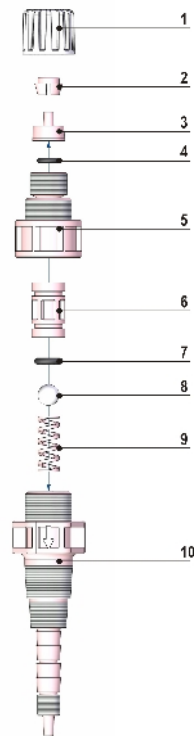

1. Ring nut
2. Bush
3. Nozzle
4. O-ring 106
5. Injection valve nipple
6. Adapter
7. O-ring 3024/3030
8. Ceramic ball
9. Spring
10. Injection valve body