



CASTLE PUMPS LTD

Industrial Pump Solutions



azcuepumps

Castle Pumps Ltd
the UK agent of Azcue





azcuepumps

Azcue Pumps have over 100 years' experience in the manufacturing of pumping solutions for applications involving water, chemicals, fuels and lubricants.

We know how important it is when sourcing a pump for an industrial process that you can be confident in its operation, that you won't be impacted by costly downtime and repairs, and that you have a robust proven solution right for your application. Azcue pumps are third party approved by Lloyds ensuring a quality level that you can rely on.

Why choose Azcue?

- ✓ Own foundry ensures complete production control
- ✓ Fast track production available on selected models
- ✓ Assured quality through 100% pump testing regime
- ✓ Type approved and available with third party witness certification by Lloyds, ABS or Bureau Veritas. Others available on request
- ✓ Complete pump packages from one manufacturer with a single warranty
- ✓ Guaranteed supply of spares for any model for a minimum of 15 years from discontinuation
- ✓ Interchangeable spares reduces stock holding
- ✓ ATEX approved models for hazardous applications
- ✓ Pumps to DIN24255 for retrofitting into existing pipework



CLOSE COUPLED
CENTRIFUGAL



Castle Pumps Ltd Azcue UK agents

Castle Pumps Ltd are the UK agent for Azcue Pumps, carrying over 90 pumps in stock, with associated spares.

We assist with specification and design for both new and replacement pumps. Due to the vast range of pump technologies, performance ranges and applications, selecting a pump can be complex. With 10 years' specialist experience we have the technical knowledge to specify a proven solution.

This combined with our maintenance facilities ensures we are your dependable partner.



Application	Centrifugal	Self Priming	Vertical Inline	Side Channel	Screw	Vertical Immersion	Progressive Cavity	Gear	Multistage	AOD	Air Operated	Barrel	Flexible Impeller	Hand	Peristaltic	Piston	Submersible	Vane
Boiler Feed	•	•		•					•									
Chemicals		•		•		•	•	•	•	•	•	•	•	•	•			
Condensate				•					•									
Cooling	•	•	•	•					•									
Dosing							•								•			
Food							•			•	•	•	•	•	•	•		
Fuel Transfer	•	•		•	•			•		•	•	•		•				•
Grease										•	•	•			•			
Hygienic										•	•	•	•		•			
Lubricants	•			•	•	•		•		•	•	•	•	•	•	•		•
Pressure Booster	•	•	•	•					•							•		
Sewage						•	•			•	•				•		•	
Sludge						•	•			•	•				•		•	
Thermal Oil	•				•			•								•		
Waste Water	•	•				•				•	•		•		•		•	
Water Circulating	•	•	•	•		•			•									

Impeller types

Options include; open impellers for handling soft particles; closed impellers for high efficiency and volatile fluids; vortex impellers for stringy solids and debris; cutter impellers for cutting up large amounts of solids; and mixed flow impellers.

Material choices

We offer pumps in a full range of materials, selected in accordance with the duty and liquid being pumped. Azcue's own foundry ensures the ability to cast in Cast Iron GG25, Ductile Iron GGG40, Bronze, Aluminium Bronze, Stainless 316 and Duplex.

Drive options

We can supply electric motors in a multitude of voltages such as single, three phase and high voltage, in both 50 and 60hz. We can also offer hydraulic, air or engine driven pumps.



SCREW PUMP

Technical considerations

Spacer coupling

Can be fitted to vertical pumps to ensure that wearing parts can be replaced without having to remove the motor.

Back pull out design

Enables the motor to be removed without disconnecting the pump from the pipework.

Magnetic coupling

Removes the need for a mechanical seal eliminating the chance of leakage and reducing service intervals.

Priming options

Azcue offer both air ejectors and electric priming pumps for applications where a short priming time is required, or where it is not possible to keep the suction flooded.

For quick lead times and to help you out in emergency situations, we offer a range of pump models and spares from stock.





Screw Pumps

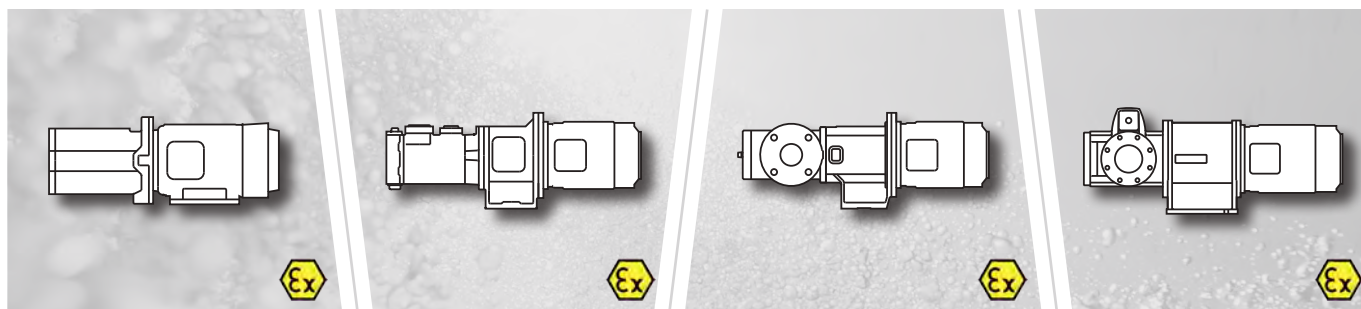

BT-MB

Close Coupled

Max Head:	50m
Q Max:	10m³/h
Max Temp:	100°C
Ports:	DN 1"-1½"

BT-HM

Spacer Coupling

Max Head:	160m
Q Max:	10m³/h
Max Temp:	160°C
Ports:	DN 1"-1½"

BT-IL

Spacer Coupled, Flanged

Max Head:	160m
Q Max:	35m³/h
Max Temp:	160°C
Ports:	DN 50-100

BT-LH

High Flow, Horizontal

Max Head:	120m
Q Max:	190m³/h
Max Temp:	160°C
Ports:	DN 125-150

Screw Pumps

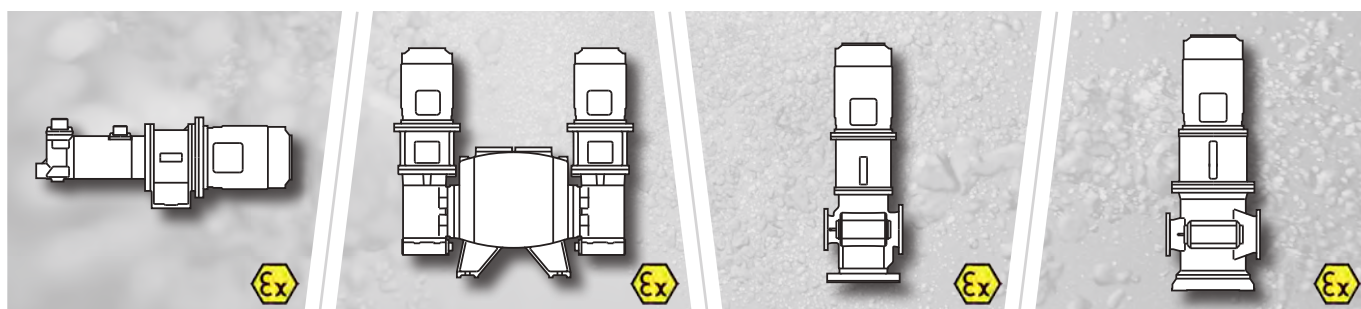

BT-HH

High Pressure, Horizontal

Max Head:	500m
Q Max:	30m³/h
Max Temp:	100°C
Ports:	DN 25-65

BLOC

Pumping Module

Max Head:	160m
Q Max:	10m³/h
Max Temp:	160°C
Ports:	DN 1"-1½"

BT-LV

High Flow, Vertical

Max Head:	120m
Q Max:	190m³/h
Max Temp:	160°C
Ports:	DN 125-150

BT-DF/DG

High Flow, Vertical

Max Head:	120m
Q Max:	450m³/h
Max Temp:	100°C
Ports:	DN 200-250

Side Channel

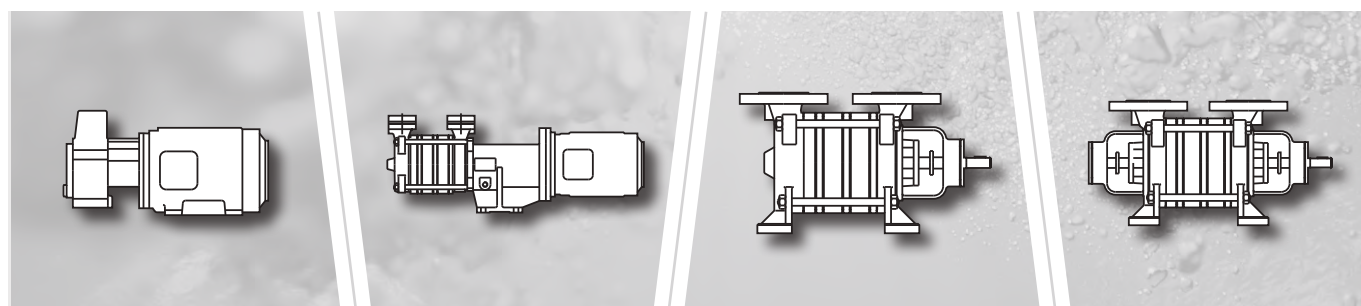

MA

Close Coupled

Max Head:	60m
Q Max:	3m³/h
Max Temp:	90°C
Ports:	DN 1"

MO

Monobloc, Multistage

Max Head:	225m
Q Max:	9m³/h
Max Temp:	90°C
Ports:	DN 1"-1½"

BR Long Coupled, Multistage

Max Head:	225m
Q Max:	45m³/h
Max Temp:	90°C
Ports:	DN 25-65

BR-RR Reinforced Long Coupled, Multistage

Max Head:	225m
Q Max:	45m³/h
Max Temp:	90°C
Ports:	DN 25-65





Vertical Inline Centrifugal

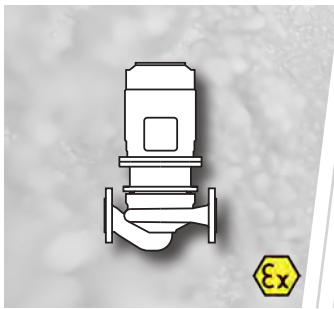

LN Close Coupled, based on DIN 24255

Max Head:	100m
Q Max:	700m³/h
Max Temp:	120°C
Ports:	DN 50-250

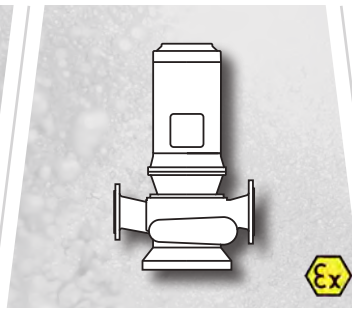

VM Close Coupled

Max Head:	130m
Q Max:	1000m³/h
Max Temp:	120°C
Ports:	DN 50-150

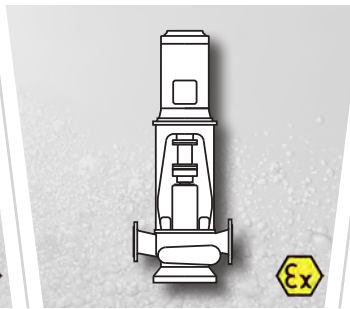

CM Close Coupled, Spacer

Max Head:	130m
Q Max:	1500m³/h
Max Temp:	120°C
Ports:	DN 50-250

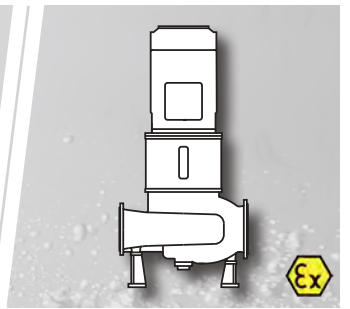

LD Long Coupled, Split Casing/Double Suction

Max Head:	60m
Q Max:	5000m³/h
Max Temp:	120°C
Ports:	DN 300-400

Vertical Inline Centrifugal

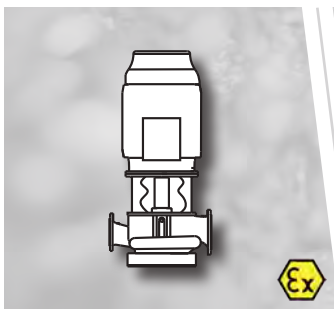

VR Close Coupled, Ball Bearing

Max Head:	130m
Q Max:	1500m³/h
Max Temp:	120°C
Ports:	DN 80-250

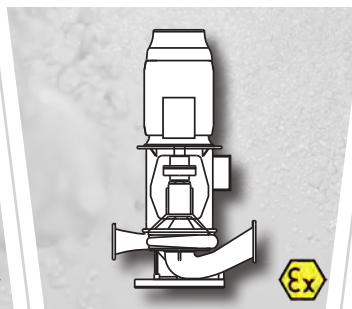

VB Long coupled

Max Head:	190m
Q Max:	2000m³/h
Max Temp:	120°C
Ports:	DN 150-250

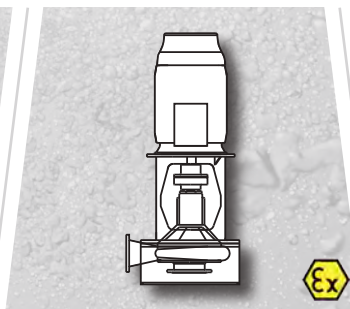

VA Long Coupled, Axial Suction

Max Head:	190m
Q Max:	2000m³/h
Max Temp:	120°C
Ports:	DN 150-250

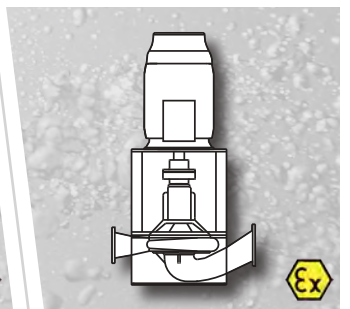

SPECIAL EXECUTIONS

Max Head:	190m
Q Max:	2000m³/h
Max Temp:	120°C
Ports:	DN 150-250

Immersed

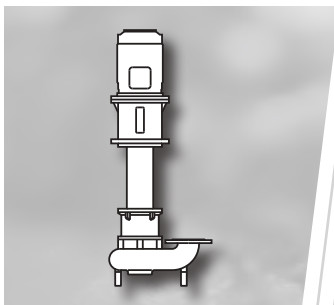

VRX Vortex Impeller

Max Head:	30m
Q Max:	500m³/h
Max Temp:	100°C
Ports:	DN 50-200

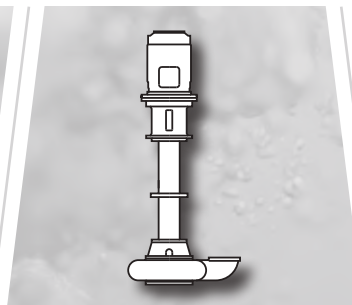

BTR Cutting Impeller

Max Head:	10m
Q Max:	80m³/h
Max Temp:	80°C
Ports:	DN 125

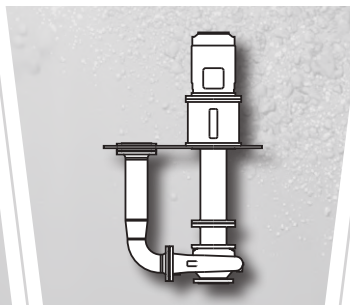

VSS Based on DIN 24255

Max Head:	100m
Q Max:	700m³/h
Max Temp:	100°C
Ports:	DN 32-150

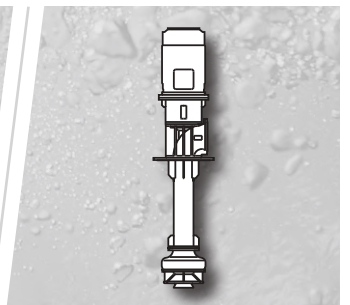

VST Based on DIN 24255, for Lube Oil

Max Head:	80m
Q Max:	2000m³/h
Max Temp:	100°C
Ports:	DN 250-350



Centrifugal

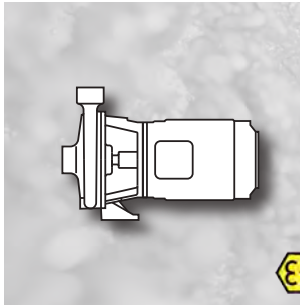

CP

Close Coupled

Max Head:	50m
Q Max:	75m³/h
Max Temp:	80°C
Ports:	DN 1"-3"

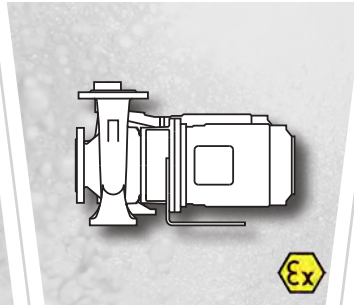

MN Close Coupled, DIN 24255

Max Head:	100m
Q Max:	500m³/h
Max Temp:	120°C
Ports:	DN 32-150

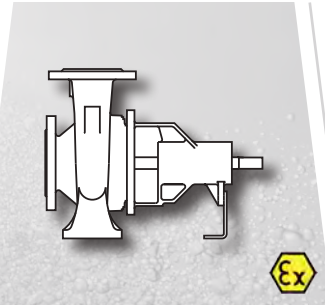

AN Long Coupled, DIN 24255

Max Head:	100m
Q Max:	700m³/h
Max Temp:	120(190)°C
Ports:	DN 32-150

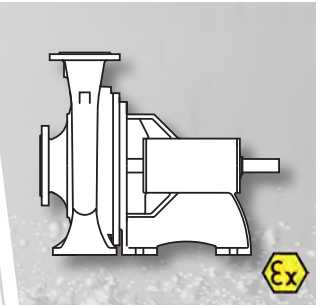

BOB Long Coupled, Flexible Coupling

Max Head:	30-150m
Q Max:	2000m³/h
Max Temp:	120°C
Ports:	DN 100-250

Centrifugal

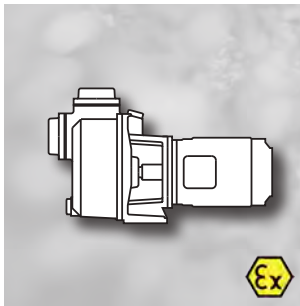

CA Self Priming, Close Coupled

Max Head:	105m
Q Max:	200m³/h
Max Temp:	90°C
Ports:	DN 1¼"-125

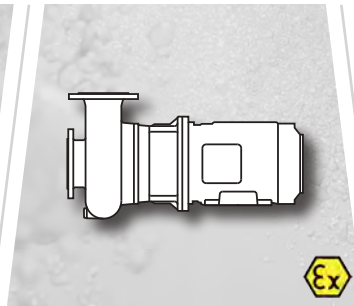

VRX Monobloc, Vortex Impeller

Max Head:	30m
Q Max:	500m³/h
Max Temp:	100°C
Ports:	DN 50-200

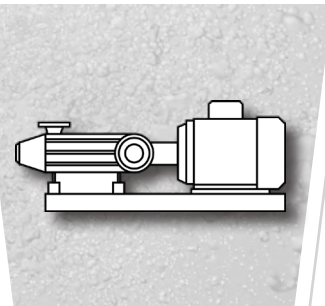

TKR Horizontal Multistage

Max Head:	600m
Q Max:	500m³/h
Max Temp:	140°C
Ports:	DN 32-150

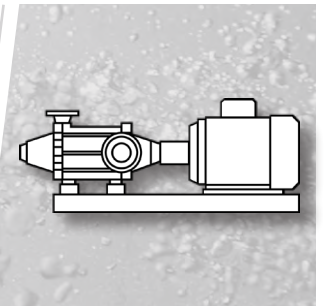

TKK Horizontal Multistage

Max Head:	900m
Q Max:	900m³/h
Max Temp:	160°C
Ports:	DN 40-250

Other Pumps

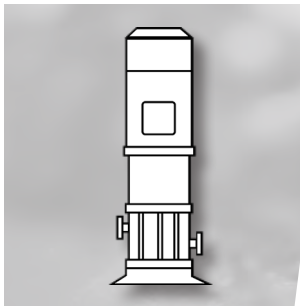

VTK

Vertical Multistage

Max Head:	400m
Q Max:	300m³/h
Max Temp:	120°C
Ports:	DN 20-150

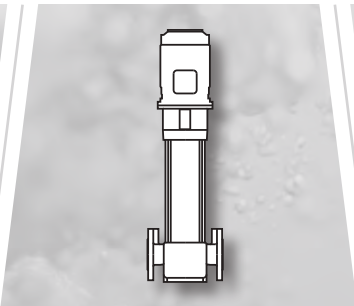

C

Vertical Multistage

Max Head:	200m
Q Max:	40m³/h
Max Temp:	120°C
Ports:	DN 1"-3"

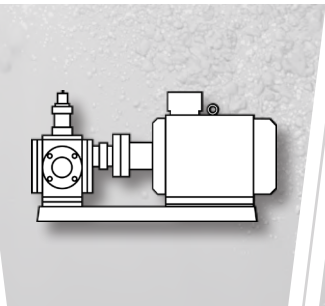

YCB

Horizontal Gear Pump

Max Head:	160m
Q Max:	97m³/h
Max Temp:	80°C
Ports:	DN 25-125



KL-KB

Eccentric Screw

Max Head:	40m (80m)
Q Max:	120m³/h
Max Temp:	80°C
Ports:	DN 80-200

Other Pumps

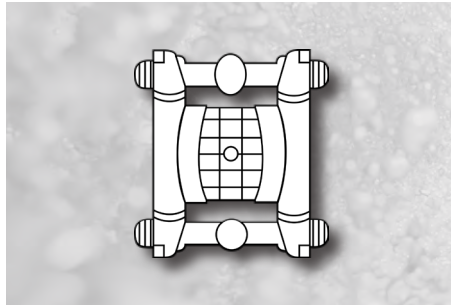

AOD

Max Head:	80m
Q Max:	70m³/h
Max Temp:	95°C
Ports:	DN ¼"-3"

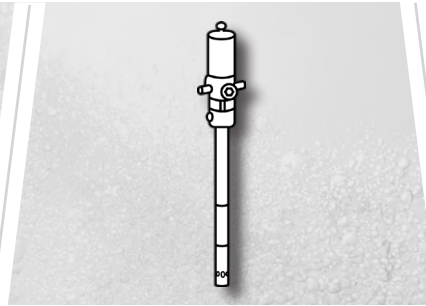

AIR OPERATED

Max Head:	5500m
Q Max:	54m³/h
Max Temp:	95°C
Ports:	DN ¾"-3"



BARREL

Max Head:	5500m
Q Max:	14m³/h
Max Temp:	150°C
Lengths:	DN 500-3000

Other Pumps

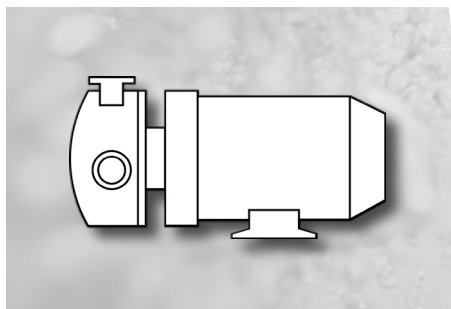

FLEXIBLE IMPELLER

Max Head:	40m
Q Max:	72m³/h
Max Temp:	100°C
Ports:	DN 19-100mm

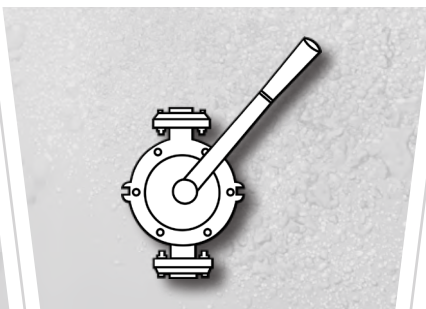

HAND

Max Head:	25m
Q Max:	8m³/h
Max Temp:	80°C
Ports:	DN ¾"-2"

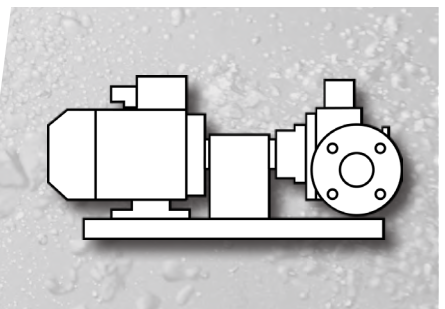

VANE

Max Head:	130m
Q Max:	110m³/h
Max Temp:	250°C
Ports:	DN ¾"-4"

Other Pumps

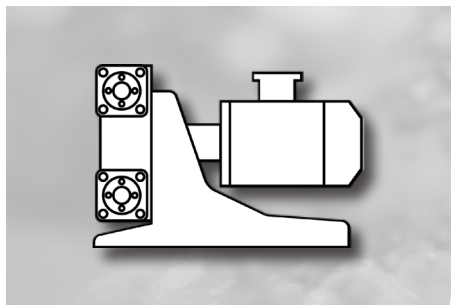

PERISTALTIC

Max Head:	150m
Q Max:	44m³/h
Solid Handling:	Up to 25mm
Ports:	DN ¾"-4"

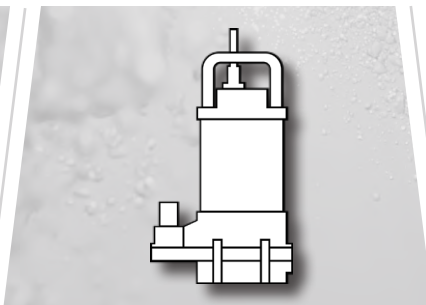

SUBMERSIBLE

Max Head:	178m
Q Max:	4800m³/h
Max Temp:	95°C
Ports:	DN 15-610mm

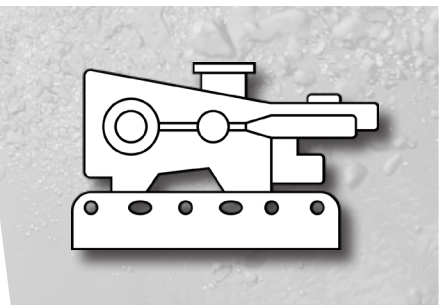

PISTON

Max Head:	6900m
Q Max:	300m³/h
Max Temp:	115°C
Ports:	DN ¼"-3"



Accredited to enable you to buy with confidence.



Why choose Castle Pumps?

- ✓ Over 10 years of technical expertise and application experience.
- ✓ Single source supplier for all pumping solutions and genuine replacement parts.
- ✓ More than just pumps - we offer valves, meters, control panels & bespoke pump kits
- ✓ We can provide 3.1 Material Certification, Certificate of Conformity, 2.1/2.2 Declaration of Compliance/Statement of Compliance and Certificate of Origin; and for export, EUR1's and attested invoices.
- ✓ Pumps are packed to ISPM15 as standard.



CASTLE PUMPS LTD

T +44 (0)1773 533 283

E sales@castlepumps.com

W castlepumps.com

Birmingham Office: Unit 40
Minworth Industrial Park, Forge Lane,
Sutton Coldfield, B76 1AH

Nottingham Office: Office 1, Denby
House, Taylor Lane, Loscoe, DE75 7AB