



CASTLE PUMPS LTD

Your process delivered.

PUMP SPECIFICATION FORM

Please return to: sales@castlepumps.com

1. Application Details -

Please fill in the table to the best of your knowledge.

Application:			
Liquid:			
Pump Orientation:	Horizontal	Vertical	Immersed
Flow Rate:			
Inlet Pressure:			
Outlet Pressure:			
Head/Pressure:			
Specific Gravity:			
Viscosity:			
Temperature:			
Voltage:			
Frequency:			
IP Protection:			

2. Hygiene Requirements -

Please answer the questions to the best of your knowledge.

How will the pump be cleaned?
How will the motor be cleaned? Does it need to be CIP?
Will the pump be dismantled for cleaning?
Motor requirements: IP Rating Jet Wash Motor Shroud
Certification: 3A EHEDG Self-Certification No Certification
Is surface finish required?
Is a drainage port required?

PTO →

(please turn over)

3. Suction Conditions -

Select **circular box** to indicate type of application, and please specify **dimension H** & **tank pressure** (where applicable) on the lines provided.

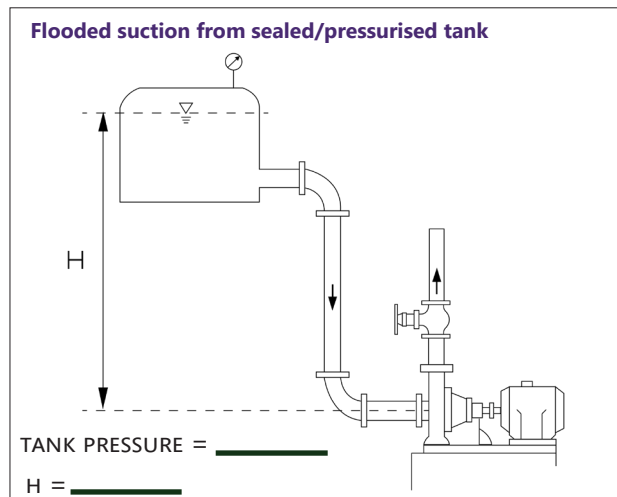
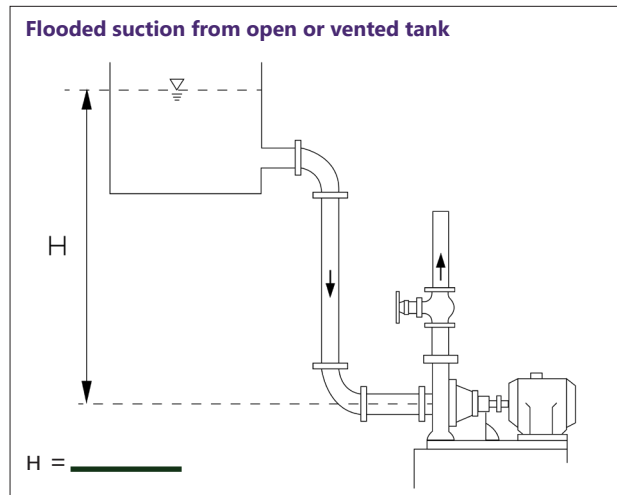
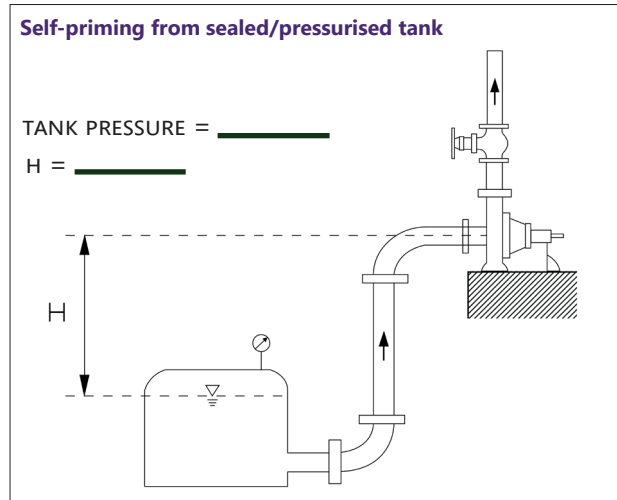
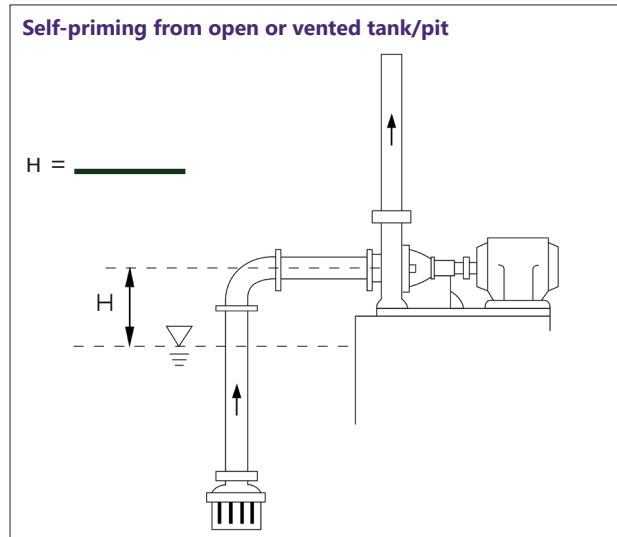

4. Installation Type -

Select **circular box** to indicate installation type, and please fill in the table referring to the diagrams where necessary.

Dimension A:	
Dimension B:	
Dimension C:	
DNa Suction Diameter:	
DNd Discharge Diameter:	
Flange Type:	
Flange Rating:	

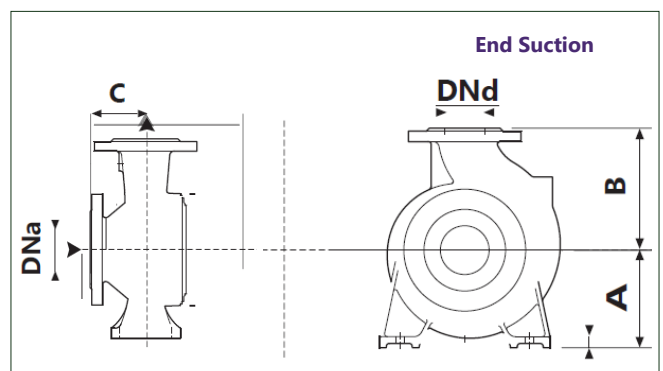
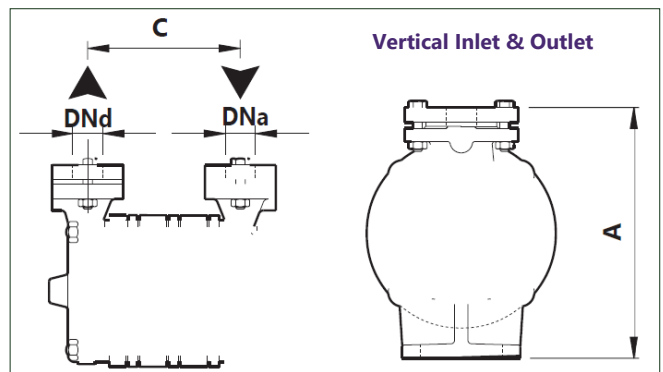
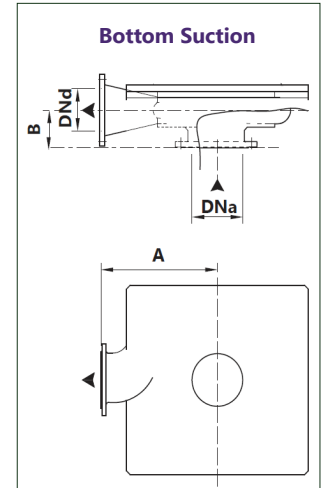
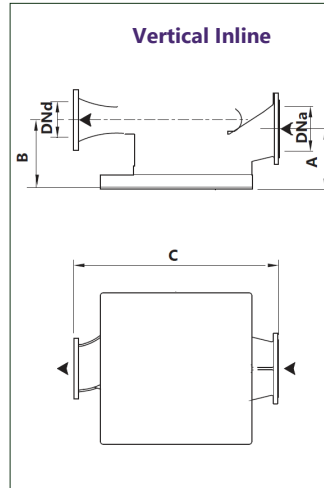

CASTLE PUMPS LTD

T +44 (0) 1773 533 283
 E sales@castlepumps.com
 W castlepumps.com

Castle Pumps Ltd
 16 Farrington Way, Eastwood,
 Nottingham, NG16 3BF